



## V-MOVE TRAILER MOVER

The V-move Trailer Mover has been specially developed to move trailers up to 40 tons. The hydraulic lifting system with Jost coupling ensures that the trailer can be coupled quickly.

The Trailer Mover is ideally suited to move trailers over short distances that normally requires a more expensive terminal tractor. The powerful electric drive ensures that full trailers can be pulled from a loading dock without difficulty. The electric drive also makes it possible to use the machine indoors where harmful exhaust gases are prohibited.

The air brakes of the trailer can be quickly released with the optional compressor. The Trailer Mover is available in two variants. A 20-ton version with a lifting capacity of 4500 kg. And a 40-ton version with 14.000 kg lifting capacity.



20T

40T

VOLTAGE / POWER	48 Volt 10 kW	48 Volt 20 kW
DRIVE	Dual Drive	Dual Drive
MOTOR	2 x 5 kW	2 x 10 kW
MAX. SLOPE	10%	10%
MAX. TOWING CAPACITY	20.000 kg	40.000 kg
LIFT HEIGHT	100 - 140 cm	100 - 140 cm
LIFT CAPACITY (KING PIN)	4.500 kg	14.000 kg
PARKING BRAKE	Hydraulic	Hydraulic
SPEED FORWARD / BACKWARD	0-5 km/h	0-5 km/h
POWERSTEERING	Optional	Standard
TIRES	Solid tires	Solid Tires
BATTERY INDICATOR	Yes	Yes
HORN	Yes	Yes
CHARGER	External	External
TYPE OF BATTERY	6 x 6 V 245 Ah maint. free	48 V 320 Ah
DIMENSION L X W X H	311 x 120 x 100 cm	327 x 154 x 100 cm
WEIGHT (INCL. BATTERIES)	2.000 kg	3.000 kg
COUPLING	Jost	Jost



### CONTROLS

The V-move Trailer Mover is easy to operate with the ergonomic tiller head. Standard equipped with stepless drive control, speed switch and anti-collision protection.



### REMOTE CONTROL

The optional remote control allows the user to keep an eye on the trailer from any angle. This considerably reduces the chance of damage



### COMPRESSOR

With the optional compressor, the air brakes of the trailer can be quickly released. In addition, a special braking system is available with which the brakes of the trailer can be used to generate extra braking power on slopes or a loading dock.



### COUPLING

The hydraulic lifting system with Jost coupling ensures that the trailer can be coupled quickly.



### TIRES

The special solid tires provide maximum traction on slippery and / or wet surfaces.



### BATTERY

The large battery pack ensures that the Trailer-Mover can be used all day long.

Dimensions 20T

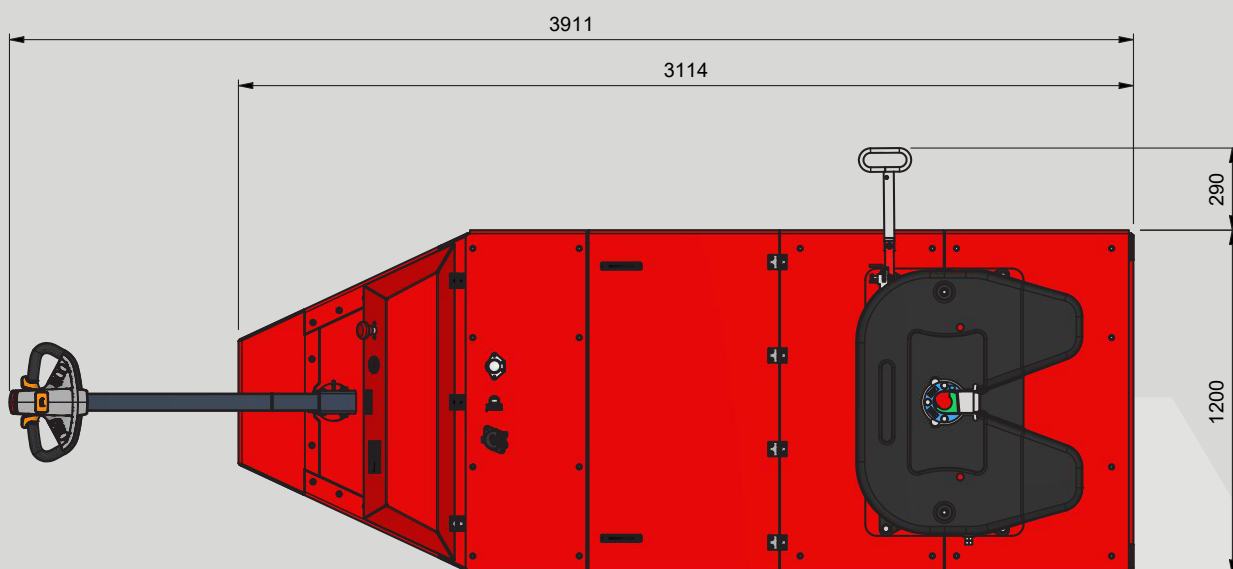
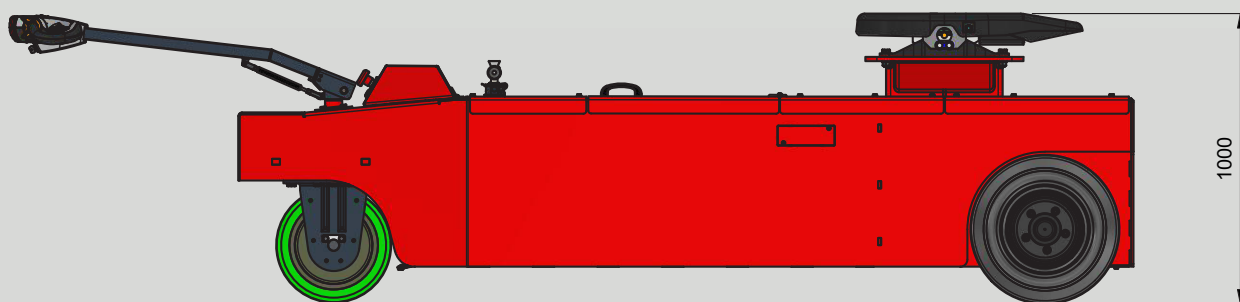
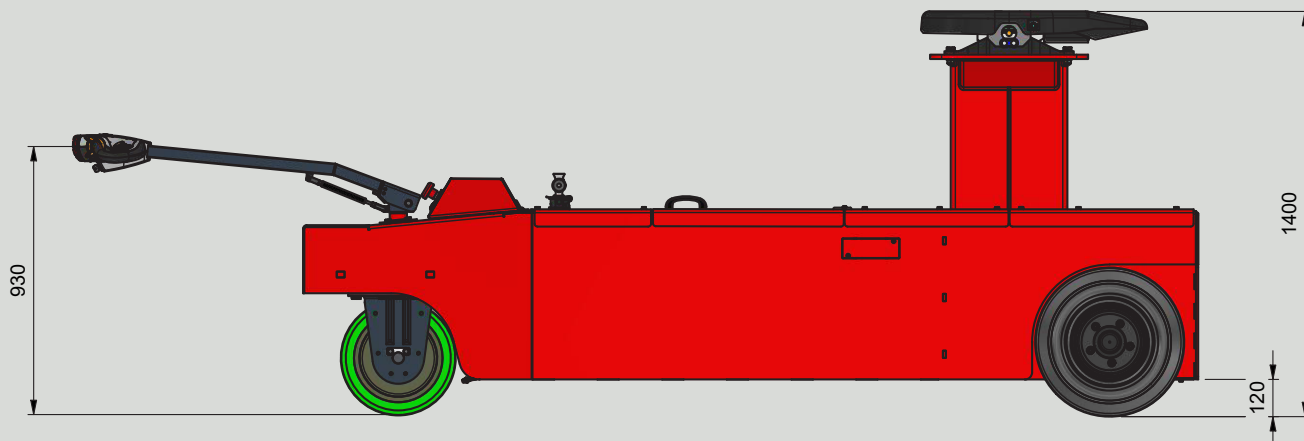

Dimensions 40T

