

RIGGING STORAGE RACK SPECIFICATIONS

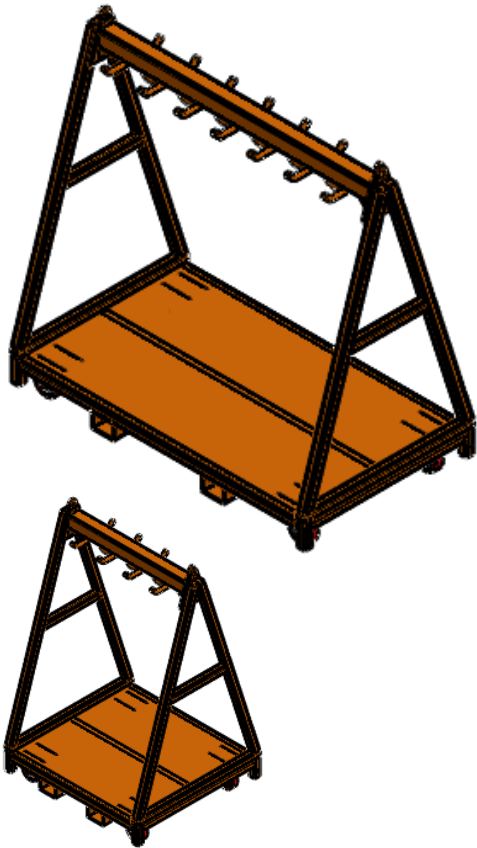

MCNG Rigging Storage Rack is the ideal solution to manage and store rigging equipment such as chains, slings, shackles, hooks and clamps when not in use. This storage rack is designed to help prevent damage and other hazards that may compromise the integrity of your lifting equipment.

With a strong 'A' frame construction for stability, this unit is fitted with hooks to store and organise your equipment. The solid based keeps your rigging equipment off the floor preventing damage. Fork pockets and crane lugs are fitted for transport by forklift or crane. For complete manoeuvrability around the workplace, removable wheels are fitted standard. Enamel paint finish.

SPECIFICATIONS:

Models	MCNG50	MCNG100
Working Load Limit (WLL)	1000kg*	1000kg*
Hanging Hooks	8	14
Length	1250mm	2000mm
Width	1150mm	1150mm
Height	2045mm	2045mm
Fork Pockets	140 x 90mm	140 x 90mm
Fork Pocket Centres	450mm	750mm
Unit Weight (incl wheels)	190kg	240kg

* evenly distributed

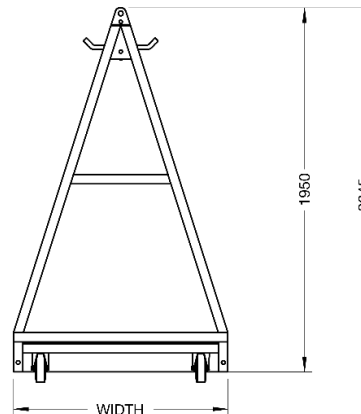
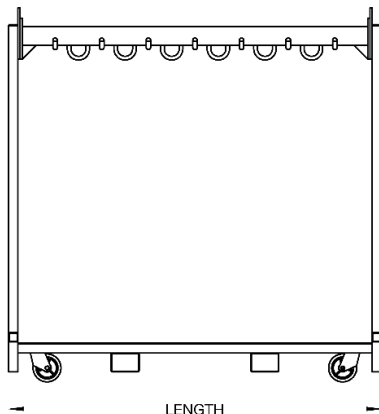
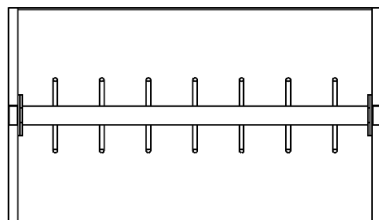

Type: MCNG100

Australia Wide Sales & Service

sales@materialshandling.com.au | www.materialshandling.com.au | 1300 65 00 35

MATERIALS
Handling PTY LTD *Working with ease.*