



# MECHRAIL

PROFESSIONAL ALUMINIUM CRANE SYSTEM



 **movomech**®

# More than 30 years at the forefront

Movomech is a complete supplier of products and solutions for professional lifting technology since 1986. Our employees consist of people who are characterised by the typical Swedish qualities of inventiveness, pride and a belief that cooperation is the key to success. This way of thinking is reflected in our products.

Through close collaboration between experienced tool-builders and skilled designers, we have over the years developed a unique approach to create optimal handling solutions for each individual assignment and meet the customer's needs.

Thanks to our broad product portfolio, we are active within most types of industry with lifting and handling needs, both in Sweden and internationally.

All our operations are located in one place. This is actually where everything started. We gain several advantages from our choice to remain in Kristianstad and establish the entire business here. It not only means that we can keep short lead times, but also that we carry the proud history that sits in the walls with us every day. This makes us better.

## 1986

Movomech is founded in Kristianstad. The same year the Mechprofile™ profile system is launched with the models MP40 and MP80 – both with a brand new sliding technology for linear units.



## 1990

An aluminium light duty overhead crane system is launched. Mechrail™ is one of the first systems of its kind in the world, and quickly becomes a preferred



## 1995

The first stepless frequency electric chain hoist, Mechchain™, is launched on the market. It revolutionises operator ergonomics in assembly work with high demands on precision and lifting experience. A new assembly line is produced and installed for Volvo Cars in Uddevalla.

## 1998

Starting this year and continuing for the next ten years, we see further growth in our range of lifting manipulators. Mechstick™, Mechstack™, Mechspace™, Vacuhand™ and Easyhand™ are launched. At the same time, more accessories are being developed for the Mechrail™ range, including the Powerdrive™ electric and pneumatic frequency drives.

## 1987

The first industrial lifting manipulator Mechlift™, is installed at Swedoor.



## 1992

Movomech raises the industry standard for operator ergonomics by developing Mechlift™ with stepless frequency control. A new professional lifting experience sees the light of day. The stronger Mechrail™ AHB1, AHB2 and AHB3 profiles are also launched this year and over the following three years.

## 1996

The Mechrail LHB profile for lighter loads is launched.





**2006**

Movomech becomes part of the Amplex group under the business area Lifting technology. The business is streamlined into two companies: Movomech AB och Movomech International AB.

From 2006 to the present day, Movomech has also been developing a solid global network of dealers in key markets for premium local support. During these years, Movomech International has consolidated its position as a specialist in system solutions for the world's largest vehicle manufacturers and manufacturing industries.



**2010**

Sunnex® premium machine mounts and workplace mats are included in the product offering.



**2017**

Movomech launches a new concept solution with mobile folding arm cranes: Mechline Pro Crane™ with integrated balance lifter. Easycrane™ with integrated vacuum lift arrives the following year.

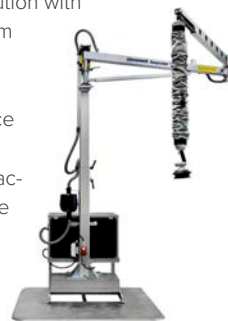

**2003**

Order and installation of an assembly line for VW Poznan. The AHB1 curve profile is developed.



**2007**

Mechrail™ PHB1 and PHB profiles are launched in this and the following year. The vacuum lift range for quick and easy handling expands.

**2012**

The pneumatic balance lifter Mechline Pro™ with lifting wire is launched and quickly becomes popular.



**2018**

The Mechrail AHB140 and AHB190 profiles are launched with a new platform of accessories.



# We are now evolving MechRail

Mechrail™ is a professional aluminium crane system that improves the working environment everywhere from world-leading companies in the automotive industry to workshops and industrial companies in most industries. And it just got even better. Our classic light duty overhead crane system has been updated with a brand new profile series. Movomech is a creative team, and is constantly developing new ideas for how the working day can be simplified for our customers in dialogue with customers, technicians, engineers and machine builders. The new profiles are a good example of this.

11% lower tare weight



Self-supporting joint set that eliminates the need for suspension points near a joint. This simplifies layout design, reduces cutting waste and, in some cases, reduces the number of necessary suspensions.

Combined nut slots on the side of the profiles that fit both ITEM 8 nuts and the standard version (20 x 5 mm) square nuts from Movomech



8% higher moment of inertia

As always from Mechrail, rolling resistance is one of the absolute lowest on the market.

More universal accessories shared by all profile sizes – reduces the number of components to stock and simplifies system configuration

8% reduction in height

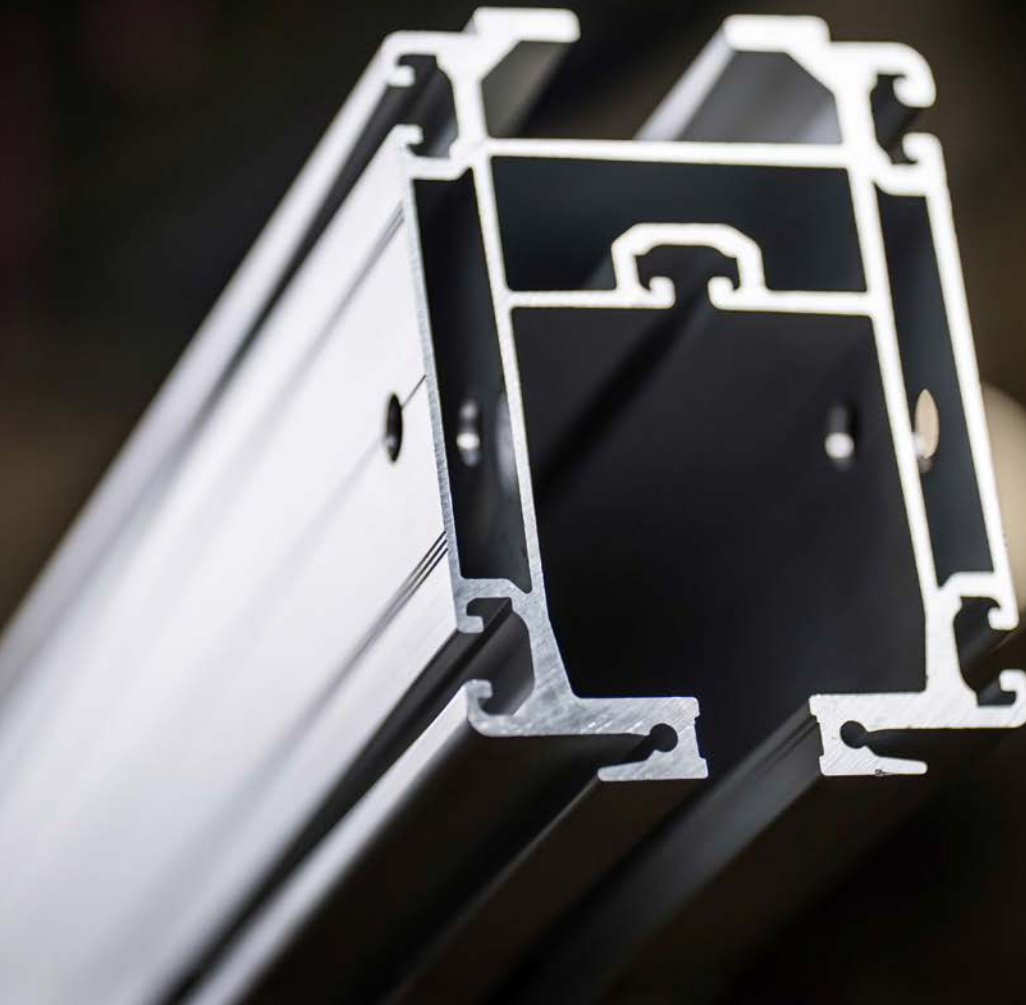

**The new Mechrail™ has many beneficial features:**

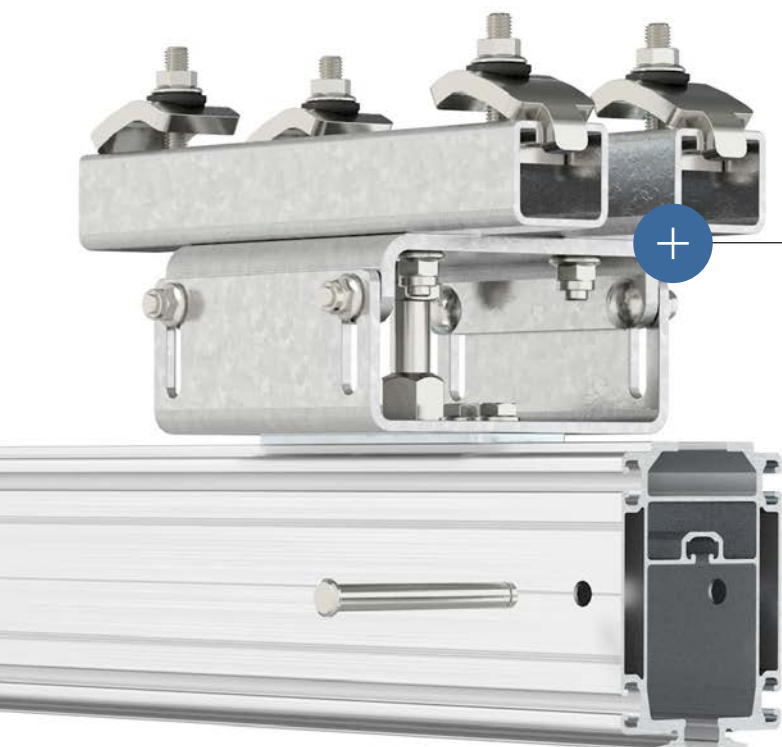

Reutilisation of the earlier geometric interface for trolleys and suspensions

End stops and end caps designed for maximum safety

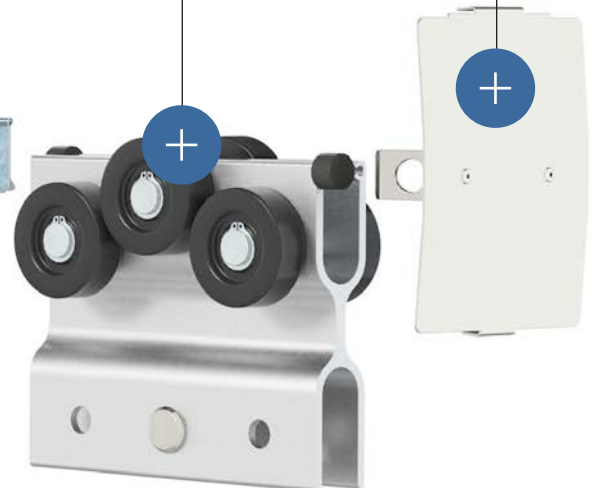

Option for integrating linear guide rails into the crane profiles. This creates several possibilities, such as raising the load capacity, designing a handling movement without play, and creating other uniquely adapted solutions.

## WORLD-CLASS LIFTING SOLUTIONS



Single crane



Double crane



Triple track



Space saving modules optimise the available height under the system



Telescopic cranes maximise the reach



External electrical power rails for a flexible installation



Mechrail™ has a modular design and can easily be adapted to any premises and handling needs.

The range offers a wide range of suspensions and smart components for pneumatic and electrical media supply. Mechrail™ can also be equipped with electric or pneumatic drive units Powerdrive™ for controlled travel movements along the x-y axis.

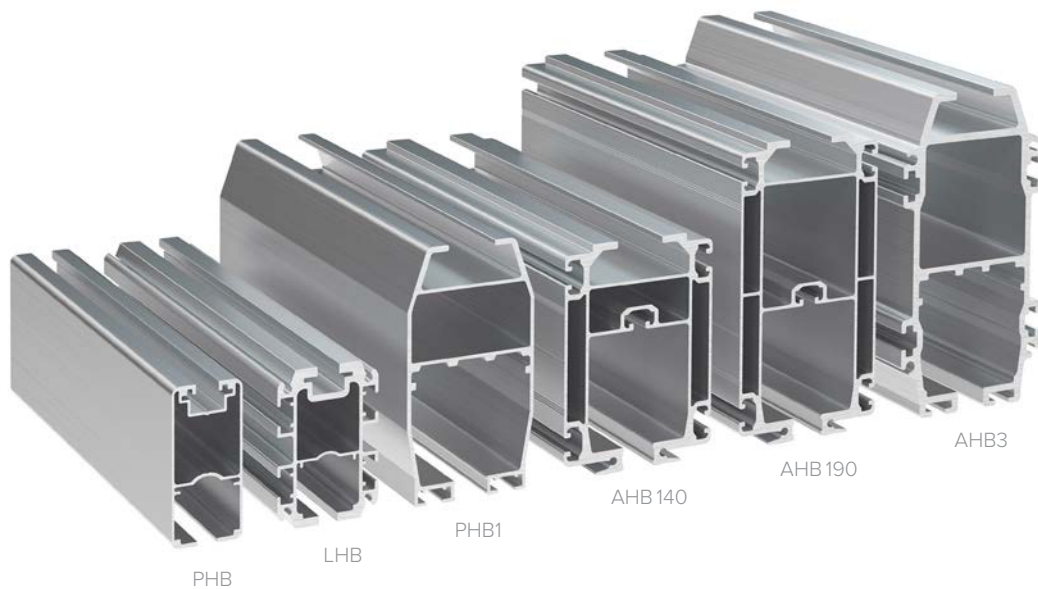

## A professional range of accessories

Mechrail™ is developed in close collaboration with operators, fitters and maintenance personnel. Therefore, our range of accessories is fully adapted to the requirements and wishes of the market. The range includes everything from service hatches, pneumatic and electric parking brakes, several variants of travel limits, position sensors, space saving modules, trolleys, suspensions with integrated wire support, and much more.

## Design for optimal ergonomics and extreme longevity

The trolleys in the Mechrail™ range have a high strength aluminium frame and are equipped with extremely easy-rolling plastic wheels with premium quality bearings.

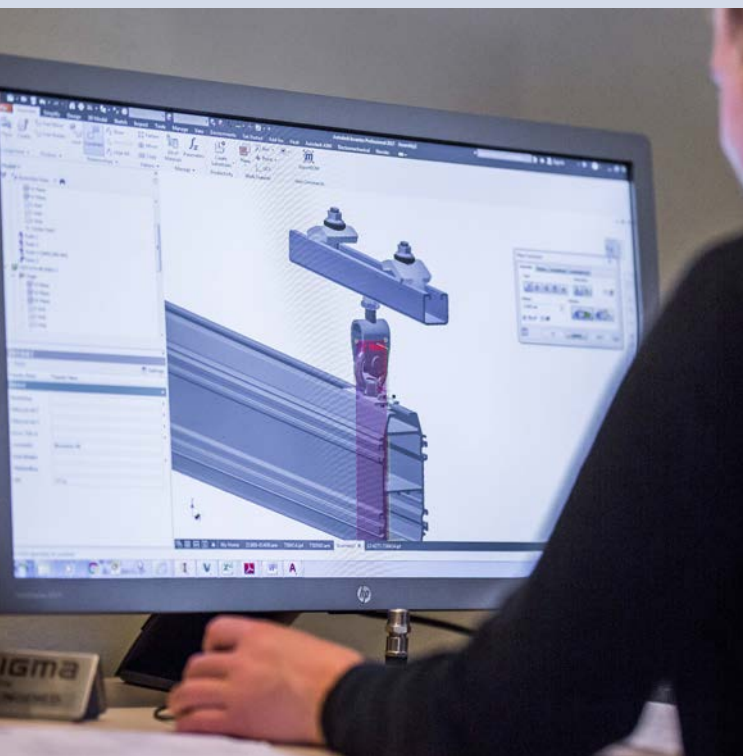

## ECONFIG™ – configuration portal

Our unique configurator EConfig™ is a popular web-based configuration and quotation system for Mechrail™. Since its launch in 2014, EConfig has facilitated the daily work of our customers with a full range of desired files and documents for your crane system. Examples of functions include price lists, component lists, assembly instructions, layout drawings, and 3D step files. The intuitive and self-instructing interface makes EConfig quick and easy to use.

## WORLD-CLASS LIFTING SOLUTIONS

Products and systems from Movomech are used in many industries in many countries. Here is a selection of customers who have chosen the Movomech companies as their partner for streamlining production processes.



### AUTOMOTIVE

Audi | Autoliv | BMW | DAF | DaimlerChrysler | Faurecia | Ford | General Motors | Jaguar | Johnson Controls | Lear Corporation | MAN | Mercedes Benz | Nissan | Renault | Opel | Peugeot | Porsche Scania | Tower Automotive | Volkswagen | Volvo AB | Volvo Cars

### LINE BUILDERS

ABB | Comau | Dürr | KUKA | Lear Corporation | Magna | ThyssenKrupp | TMS | VDL Steelweld

### OTHER INDUSTRY

ABB | Airbus | Alfa Laval | Arla | Arvin Meritor | Atlas Copco Secoroc | Atlas Copco Tools | Astra Zeneca | Ballingslöv | BT Industries | Cardo | Carglass | Carlsberg Sverige | Daloc | Danfoss | Doria DynaMate | Dynapac | Electrolux | European Furniture Group | Finja | GGP Sweden | Gustavsberg Husqvarna | IFÖ | Kilsgaard | Kinnarps | Orresta | Outokumpu | Pilkington | Randek BauTech | Saab AB | Schenk | SKF | Statoil | Swedoor | Tarkett | Westinghouse

Australia Wide Sales & Service

[sales@materialshandling.com.au](mailto:sales@materialshandling.com.au) | [www.materialshandling.com.au](http://www.materialshandling.com.au) | 1300 65 00 35

**MATERIALS**  
**Handling** PTV LTD *Working with ease.*