

# SITE TOOL BOX MBJL9 SPECIFICATIONS



The MBJL9 Site Tool Box is designed as a secure storage solution on work sites that can be transported by overhead crane and forklift.

## FEATURES:

- Heavy duty, weatherproof construction
- Fitted with crane lugs and fork pockets for easy relocation
- Tamper proof, lockable double door provides security against theft
- Designed & certified in accordance with Australian Standards
- Wheels fitted (removable)
- Enamel paint finish

## SPECIFICATIONS:

Working Load Limit (WLL)	1000 kg
Opening Dimensions	920 x 920 mm
Overall Dimensions	1105 x 1105 x 980 mm
Unit Weight	155 kg
Fork Pocket Size	155 x 55 mm
Fork Pocket Centres	666 mm

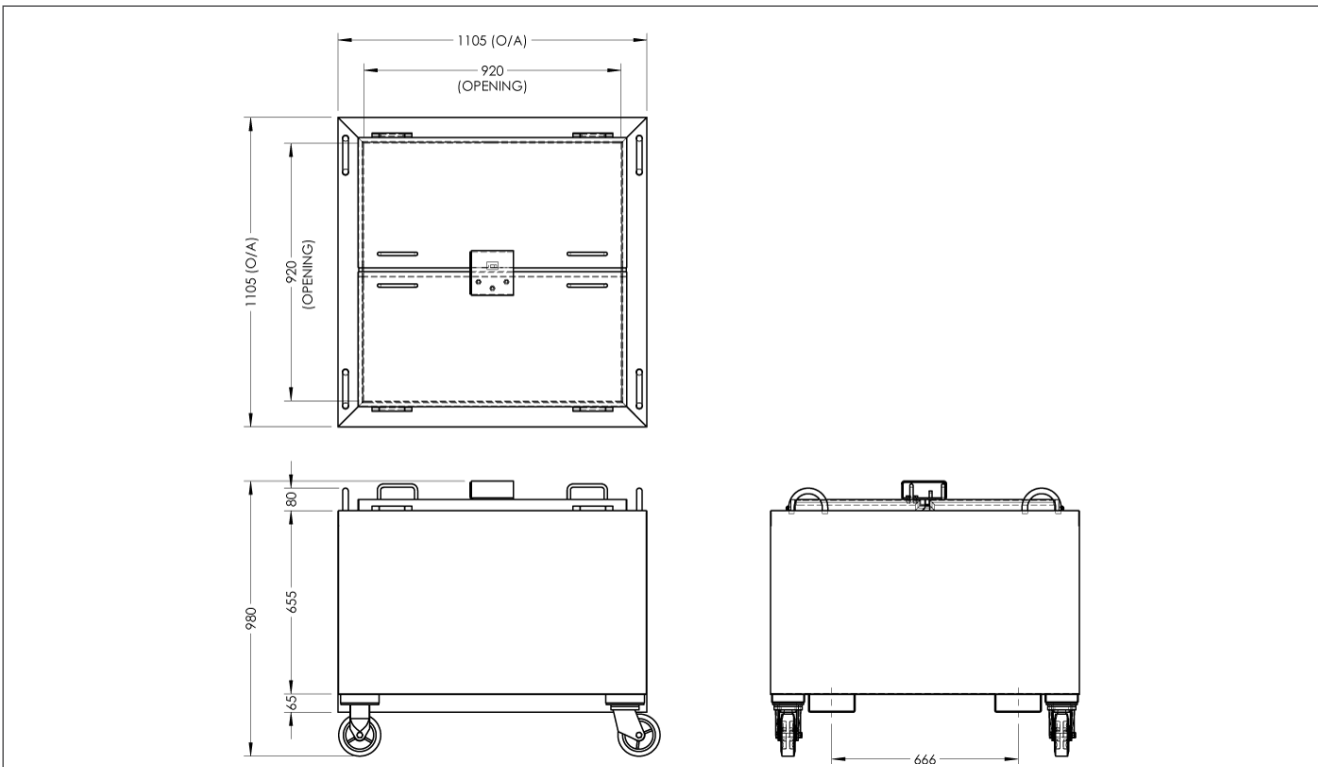

Australia Wide Sales & Service

sales@materialshandling.com.au | www.materialshandling.com.au | 1300 25 84 07

**MATERIALS**  
**Handling** PTY LTD *Working with ease.*