

SIDWAYS DRUM ROTATOR DSWNH-PBO SPECIFICATIONS

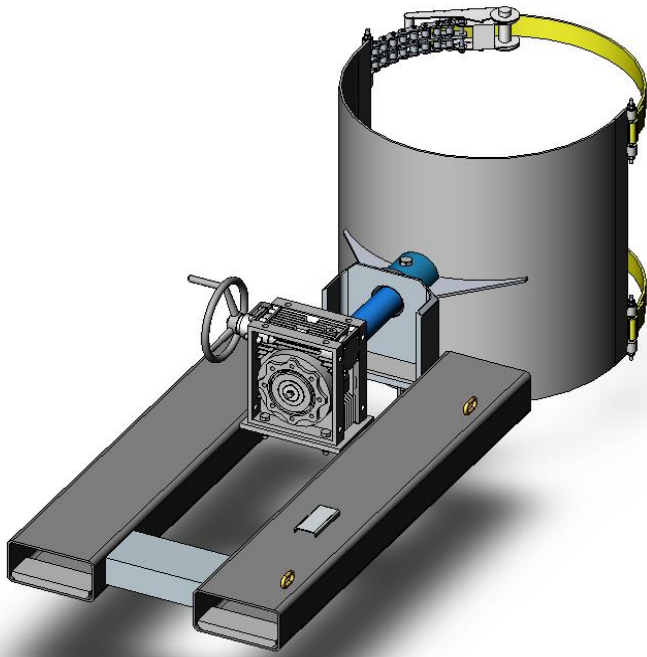

The DSWNH-PBO Sideways Drum Rotator is designed to lift and rotate drums with varying diameters, including standard Plastic Drums as well as barrels - through 360-degree perpendicular to the fork arms. Handle rotation via a Gearbox of the drum cradle ensures minimum effort for fully controlled tipping, allowing complete emptying of the drum contents. Dual woven/chain combination Belly Straps with ratchet tightening for clamping hold the Drum firmly in position.

This slip-on attachment requires only the connection of a safety chain to a narrow carriage Forklift. The standard finish of this unit is painted enamel.

SPECIFICATIONS:

- Working Load Limit (WLL): 350 kg
- Unit Weight: 132 kg
- Load Centre: 1500 mm
- Horizontal C of G: 860 mm
- Vertical C of G: 32 mm
- Pocket Size: 185 x 65 mm
- Pocket Centres: 430 mm
- 360° Rotation

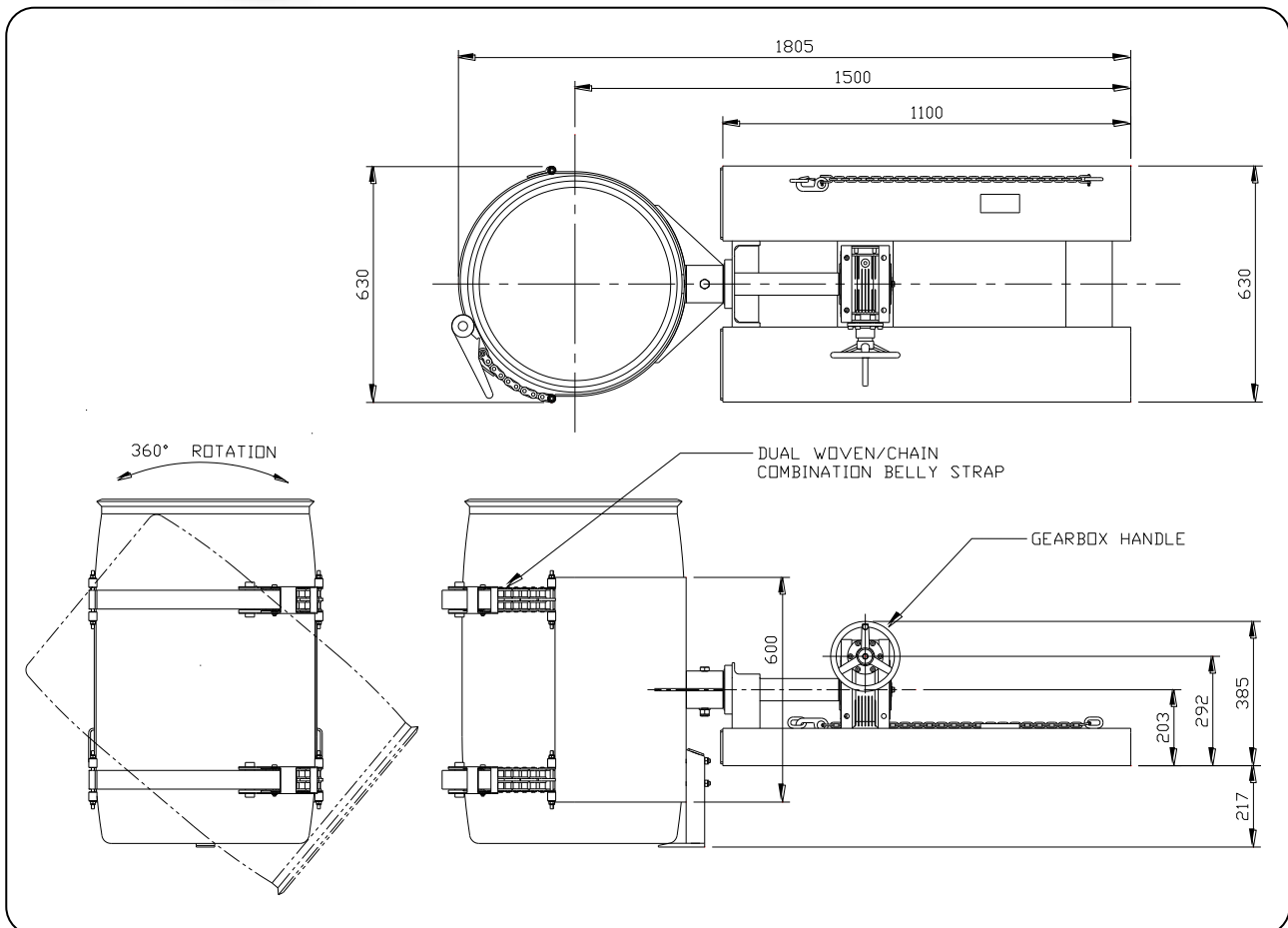

Australia Wide Sales & Service

sales@materialshandling.com.au | www.materialshandling.com.au | 1300 25 84 07

MATERIALS
Handling PTY LTD *Working with ease.*