

SERIES 2000 MATERIALS LIFTER SPECIFICATIONS

Series 2000 Features:

- ▶ Lifts up to 455 kg
- ▶ 3.5, 4.9 and 7.7 m foot heights
- ▶ No tools required
- ▶ No loose hardware
- ▶ Mast hold-down secures mast for safe transport
- ▶ Built for heavy materials and continuous work.

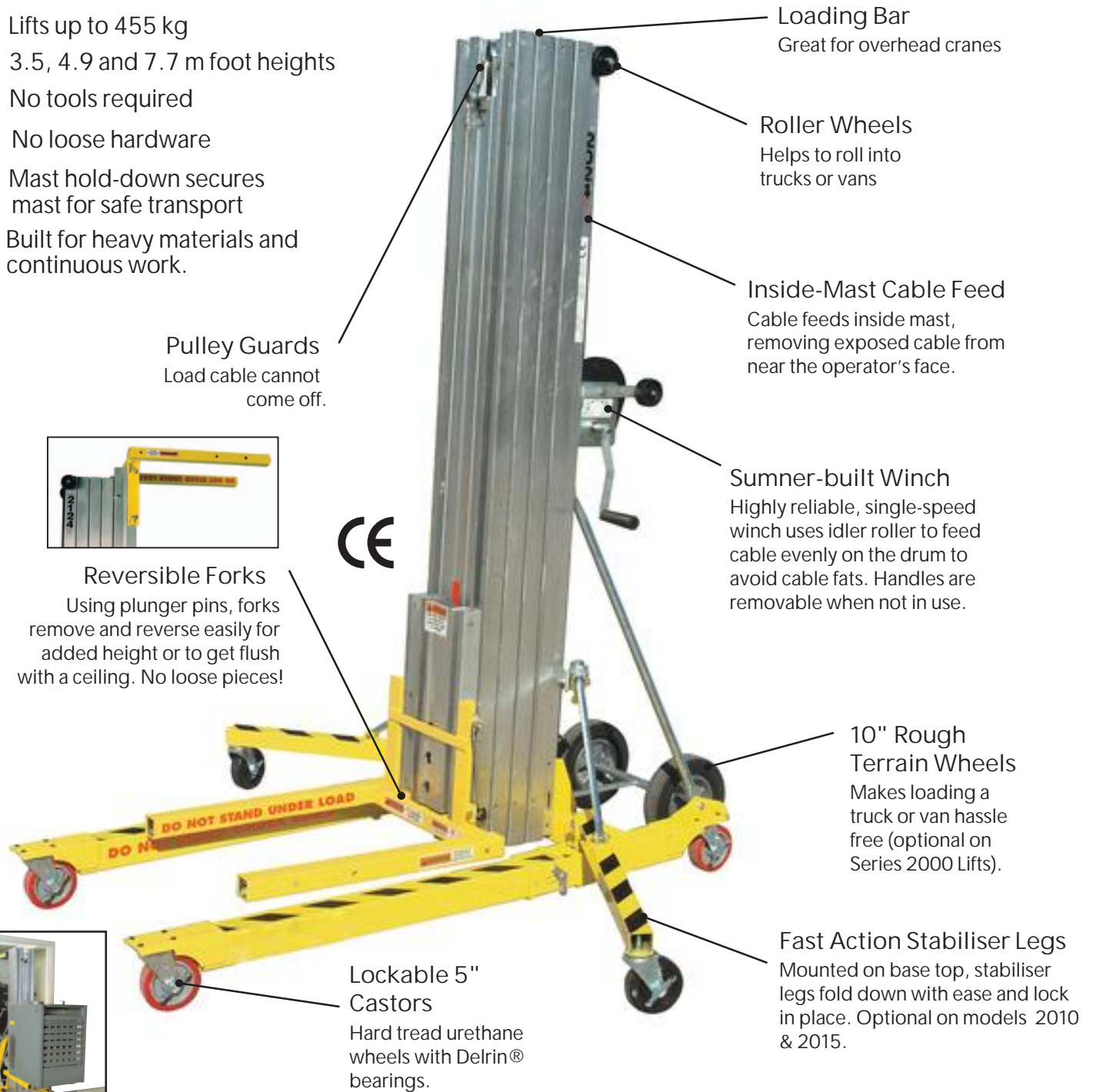

Pulley Guards
Load cable cannot come off.



Reversible Forks
Using plunger pins, forks remove and reverse easily for added height or to get flush with a ceiling. No loose pieces!



Fits through doorways!

Australia Wide Sales & Service

sales@materialshandling.com.au | www.materialshandling.com.au | 1300 25 84 07

Available in optional galvanised finish! (#776270)



One piece slide-lock mechanism releases with plunger pins to fold legs. Leg rollers allow lift to be wheeled around with legs in stored position.

Boom Carriage (#783642)

- ▶ Ideal for installing pipe or other lifting applications
- ▶ Attaches with four plunger pins
- ▶ 100 cm reach
- ▶ Five (5) hooking options
- ▶ Load capacity decrease when the boom is extended, from 300 to 90 kg



Pipe Cradle (#783705)

- ▶ Great for duct pipe or other HVAC applications
- ▶ Slides over standard forks.

Fork Extensions (#783691)

- ▶ Push-button operation
- ▶ Extend forks from 71 cm to 106 cm
- ▶ Longer forks decreases weight capacity to 90 kg (clearly displayed on the forks when extended)



| Series 2000 Material Lift Dimensions | M2010 | | M2015 | | M2025 | |
|--------------------------------------|------------|---------|------------|---------|------------|---------|
| Height - stowed | 6' 4" | 1.93 m | 6' 4" | 1.93 m | 6' 4" | 1.93 m |
| Length - stowed | 34" | 0.86 m | 34" | 0.86 m | 34" | 0.86 m |
| Height - operating | 6' 4" | 1.93 m | 6' 4" | 1.93 m | 6' 4" | 1.93 m |
| Length - operating | 5' 2" | 1.57 m | 5' 2" | 1.57 m | 6' 1" | 1.84 m |
| Base width | 31-1/4" | 0.80 m | 31-1/4" | 0.80 m | 31-1/4" | 0.80 m |
| Width with stabilizer legs | 6' 2" | 1.88 m | 6' 2" | 1.88 m | 6' 2" | 1.88 m |
| Ground clearance | 2-1/2" | 6.4 cm | 2-1/2" | 6.4 cm | 2-1/2" | 6.4 cm |
| Load height (minimum) | 6" | 15.2 cm | 6" | 15.2 cm | 6" | 15.2 cm |
| Maximum height (forks down) | 9' 7-1/2" | 2.9 m | 14' 2-3/4" | 4.3 m | 23' 5-3/8" | 7.1 m |
| Maximum height (forks reversed) | 11' 7-1/8" | 3.5 m | 16' 2-1/2" | 4.9 m | 25' 5-1/8" | 7.7 m |

| Part No. | Description | Max Height | | Lifting Capacity | | Lift Weight | | Shipping Weight | |
|----------|--------------------|------------|-------|------------------|-----|-------------|-------|-----------------|-------|
| | | Feet | Meter | lb | kg | lb | kg | lb | kg |
| 783700 | 2010 Material Lift | 11' 7-1/8" | 3.5 | 1,000 | 455 | 188 | 85.5 | 223 | 104.4 |
| 783701 | 2015 Material Lift | 16' 2-1/2" | 4.9 | 800 | 360 | 280 | 127.3 | 315 | 143.2 |
| 783703 | 2025 Material Lift | 25' 5-1/8" | 7.7 | 650 | 300 | 430 | 195.5 | 465 | 211.4 |

| Part No. | Description |
|----------|---------------------|
| 783882 | Safety brake - 2010 |
| 783883 | Safety brake - 2015 |
| 783885 | Safety brake - 2025 |

Safety Brake

Each mast and carriage can have a factory installed, gravity actuated safety brake which holds loads in place in the event the cable should go slack.

Australia Wide Sales & Service

sales@materialshandling.com.au | www.materialshandling.com.au | 1300 25 84 07

MATERIALS
Handling PTY LTD Working with ease.