

SITE STORAGE BOXES SBS SPECIFICATIONS

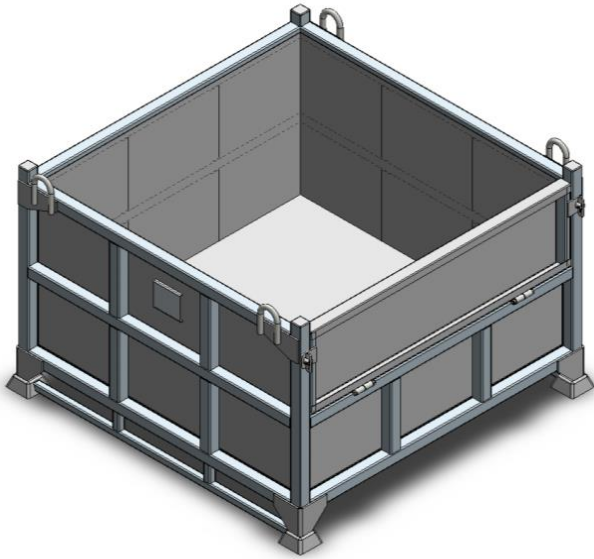

The type SBS Heavy Duty Storage Boxes are designed for secure handling of heavy weight components/parts in and around your workshop or during transport.

All Storage Boxes feature a half drop-down Front Panel for ease of access when stacked. The type SBS115 version has reinforced support bars for use with high bay racking.

The SBS Storage Boxes can be transported by Forklift or Crane and are stackable up to 4 high when fully loaded.

SPECIFICATIONS:

- Working Load Limit (WLL): 1000kg
- Zinc Plated Finish
- Refer below for all other Specifications

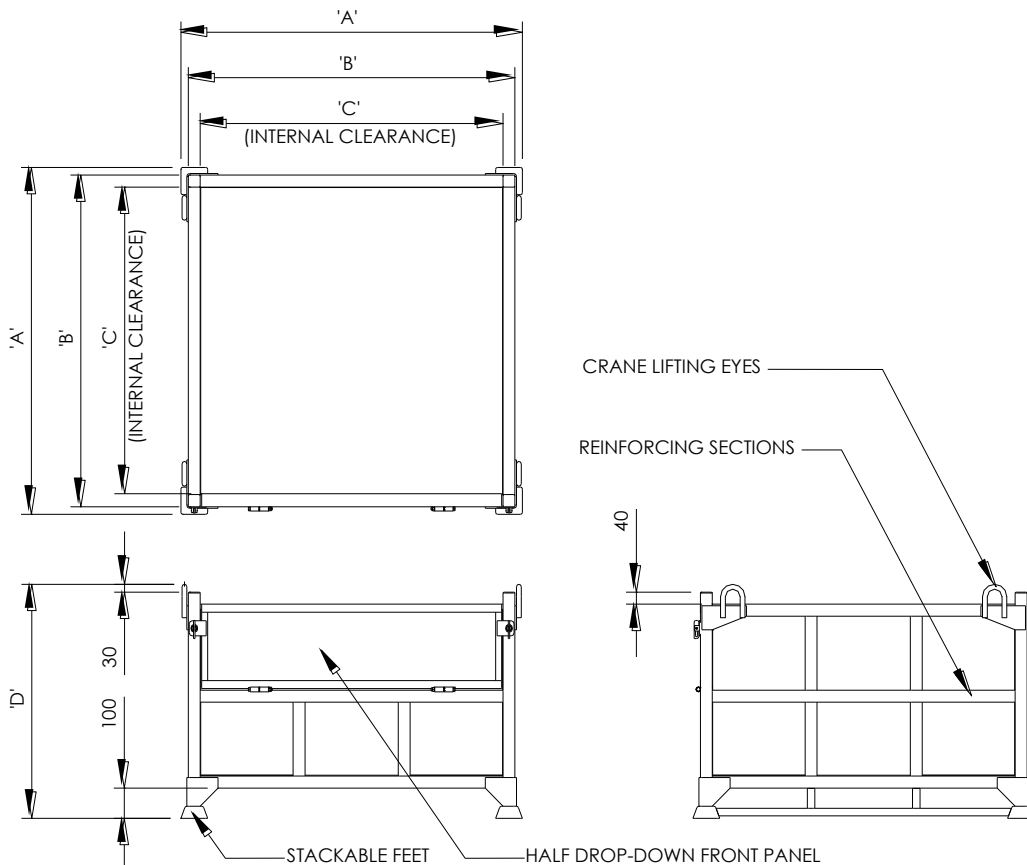

TYPE	Dimensions (mm)				Volume (litres)	Unit Weight (kg)
	'A'	'B'	'C'	'D'		
SBS 75	750	700	620	620	158	58
SBS 115	1150	1100	1020	780	580	115