

# MOBILE DRUM TROLLEY DTSC2 SPECIFICATIONS

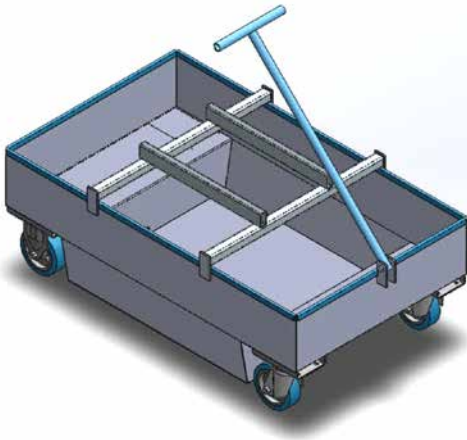

The DTSC2 Mobile Drum Trolley is designed to safely and easily move a standard 205 litre drum in either horizontal or vertical position with the added spill bin protection against costly and environmentally damaging chemical spills. This is a robust and heavy-duty drum handling solution that improves productivity.

## FEATURES:

- Suits storage of a standard 205 litre drum, primarily in horizontal position
- Heavy duty castors and towing handle allow effortless movement around the work-site
- Drain plug fitted to allow emptying of the containment area
- Provides a spill capacity exceeding the Australian Standards for 'portable' units
- Zinc finish



## SPECIFICATIONS:

|                          |         |
|--------------------------|---------|
| No. of Drums             | 1       |
| Working Load Limit (WLL) | 1000 kg |
| Unit Weight              | 50 kg   |

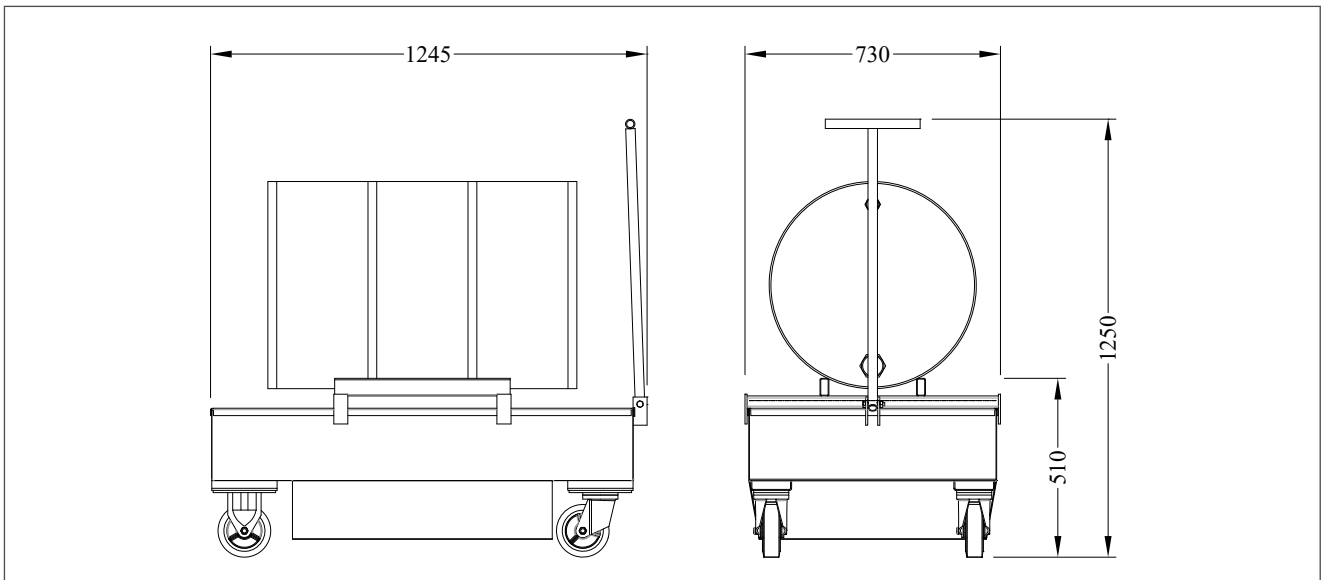

NOTE: Reference should be made to AS1940 and other relevant Australian Standards in regards to the maximum capacity allowed for the storage of flammable, dangerous or combustible liquids and necessary precautions required along with minimum separation distances. This unit exceeds the minimum spill capacity requirements of a portable bunding unit used for transit storage as per standard AS1940 (Flammable & Combustible Liquids), AS3780 (Corrosive Substances) and AS/NZS 3833 (Dangerous Goods).

Australia Wide Sales & Service

sales@materialshandling.com.au | www.materialshandling.com.au | 1300 25 84 07

**MATERIALS**  
**Handling** PTY LTD *Working with ease.*