

VERTICAL BALERS

MWP75 SPECIFICATIONS



BALER DIMENSIONS

Height	2.300 m
Width	1.04 m
Depth	0.720 m
Weight	270 kg
Transportation Height	1.80 m
Power Supply	230V 1 Phase
Motor	1.5kW 13A
Pressing Force	Up to 3.5 T
Noise Level	72 dB
Cycle Time	24 Seconds

BALE DIMENSIONS

Height	1.000 m
Width	0.700 m
Depth	0.500 m
Weight	Up to 75 kg

LOADING APERTURE SIZES

Height	0.698 m
Width	0.70 m

75 BALER FEATURES

- ▶ Suitable for positioning where storeroom space is limited.
- ▶ Easy to operate.
- ▶ For small to medium volumes of waste.

OPTIONAL EXTRAS

- ▶ Available with 110-115 volts single phase, 380-400 volt 3-phase power supplies.
- ▶ Can Crusher Insert: For compaction of drinks cans and food tins from 5 Lt - 20 Lt. The Crusher Insert raises the floor in the baler chamber to allow the press head to compact.
- ▶ Galvanised finish.
- ▶ Bale Lifting Trolley.



Australia Wide Sales & Service

sales@materialshandling.com.au | www.materialshandling.com.au | 1300 25 84 07

MATERIALS
Handling PTY LTD *Working with ease*

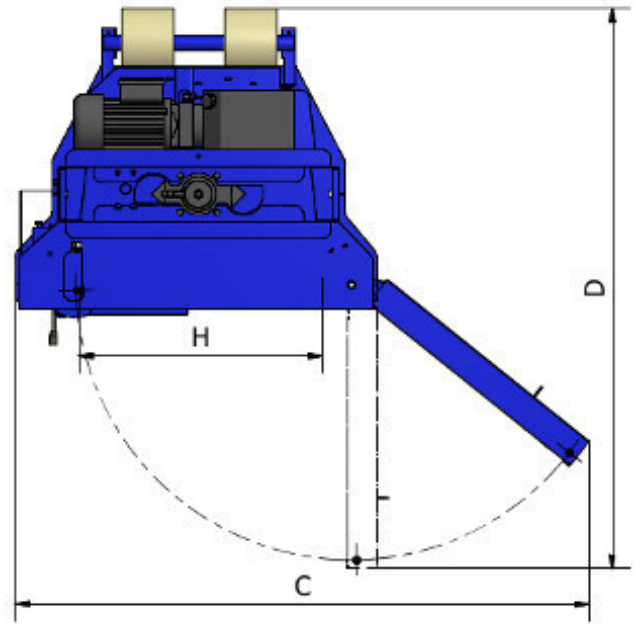
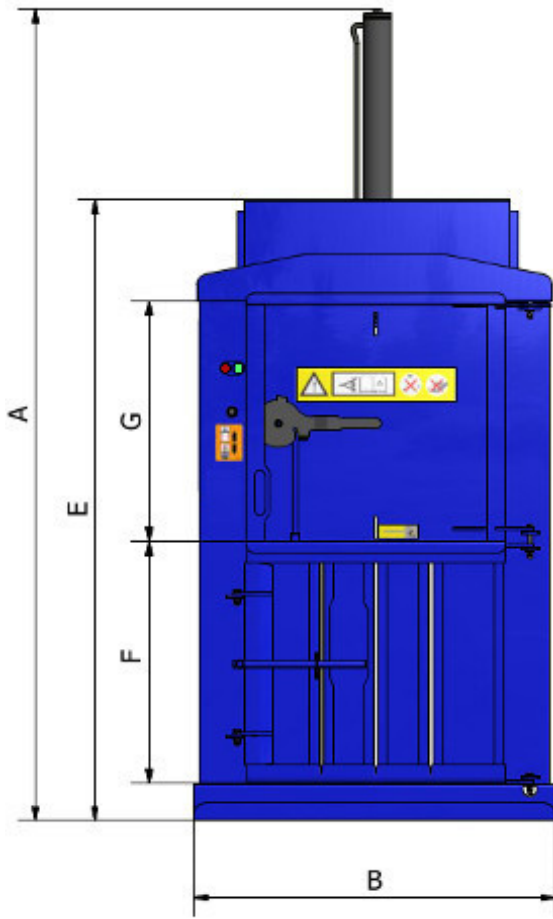

A 2.300 m

B 1.040 m

C 1.652 m

D 1.612 m

E 1.786 m

F 0.695 m

G 0.691 m

H 0.700 m

Australia Wide Sales & Service

sales@materialshandling.com.au | www.materialshandling.com.au | 1300 25 84 07

MATERIALS
Handling PTV LTD *Working with ease*