

# VERTICAL BALERS

## MWP60 SPECIFICATIONS



### BALER DIMENSIONS

Height	1.980 m
Width	1.040 m
Depth	0.720 m
Weight	230 kg
Transportation Height	1.63 m
Power Supply	230V 1 Phase
Motor	1.5kW 13A
Pressing Force	Up to 3.5T
Noise Level	72 dB
Cycle Time	24 Seconds

### BALE DIMENSIONS

Height	0.800 m
Width	0.700 m
Depth	0.500 m
Weight	Up to 60 kg

### LOADING APERTURE SIZES

Height	0.492 m
Width	0.700 m

## 60 BALER FEATURES

- Compact design makes this machine ideal for locations where space is at a minimum e.g. garage fore courts, retail outlets, offices, pubs etc.
- Suitable for small volumes of waste.

## OPTIONAL EXTRAS

- Bale lifting trolley.
- Available with 110 volts power supply.
- Available with 3-phase 380/400 volt power supply.
- Galvanised finish.
- PLC Panel with automatic compaction cycles and baler full light.



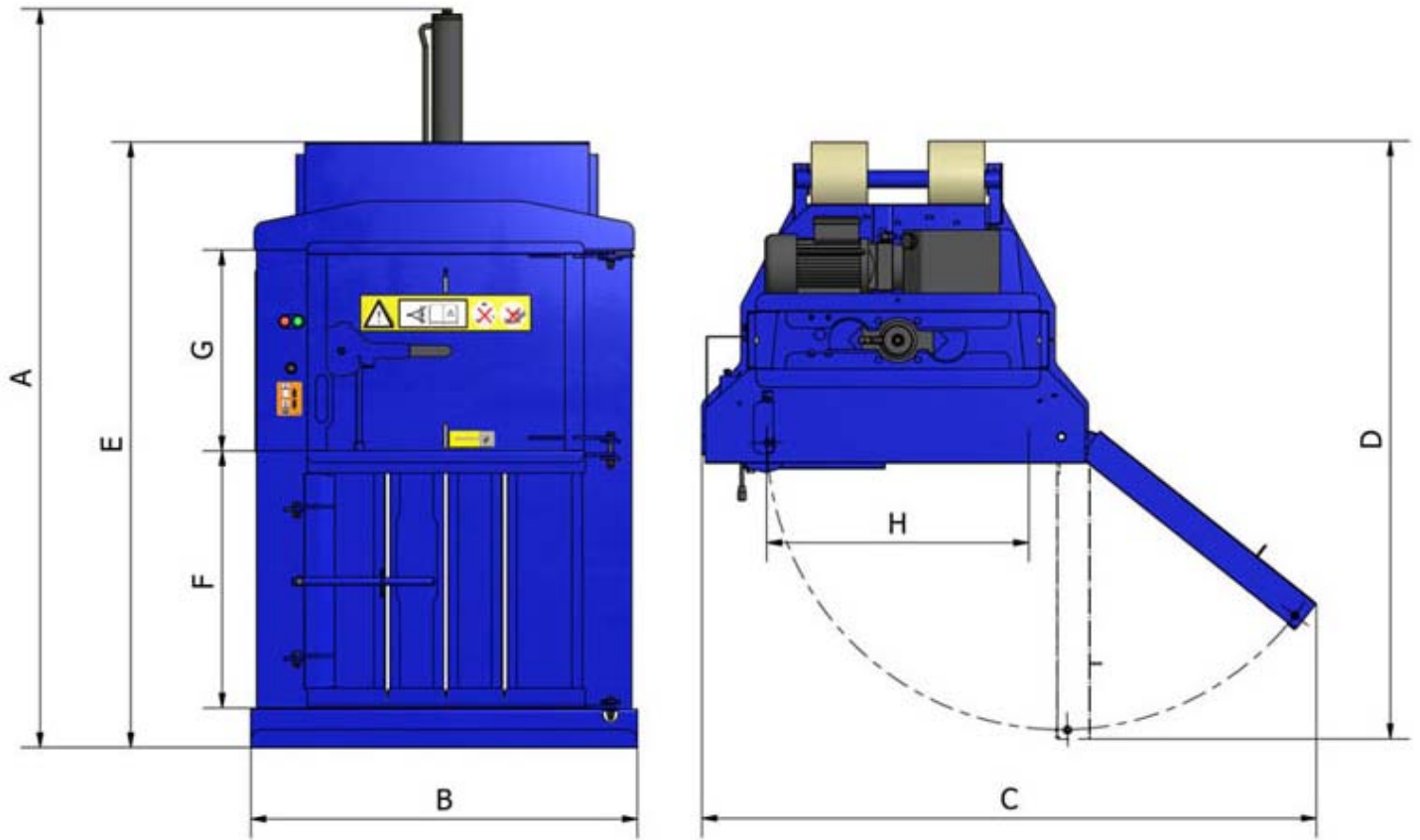

A 1.980 m

B 1.040 m

C 1.652 m

D 1.615 m

E 1.636 m

F 0.695 m

G 0.542 m

H 0.700 m