

VERTICAL BALERS

MWP101 SPECIFICATIONS



BALER DIMENSIONS

Height	2.370 m
Width	1.400 m
Depth	0.995 m
Weight	585 kg
Transportation Height	1.800 m
Power Supply	240V 1 Phase
Motor	2.2kW 16A
Pressing Force	Up to 6.0 T
Noise Level	64-68 dB
Cycle Time	34 Seconds

BALE DIMENSIONS

Height	0.800 m
Width	1.000 m
Depth	0.800 m
Weight (Cardboard)	Up to 110 kg

LOADING APERTURE SIZES

Height	0.550 m
Width	1.000 m

101 BALER FEATURES

- Retaining claws to prevent spring back of material.
- Fully automatic bale ejector: simplifies bale removal.
- A mid range baler with easy loading for large boxes.
- PLC Panel with automatic compaction cycles.
- Bale full light.

OPTIONAL EXTRAS

- Galvanised finish.
- Sliding top door for easy loading of material.
- 3-Phase 415V power supply.



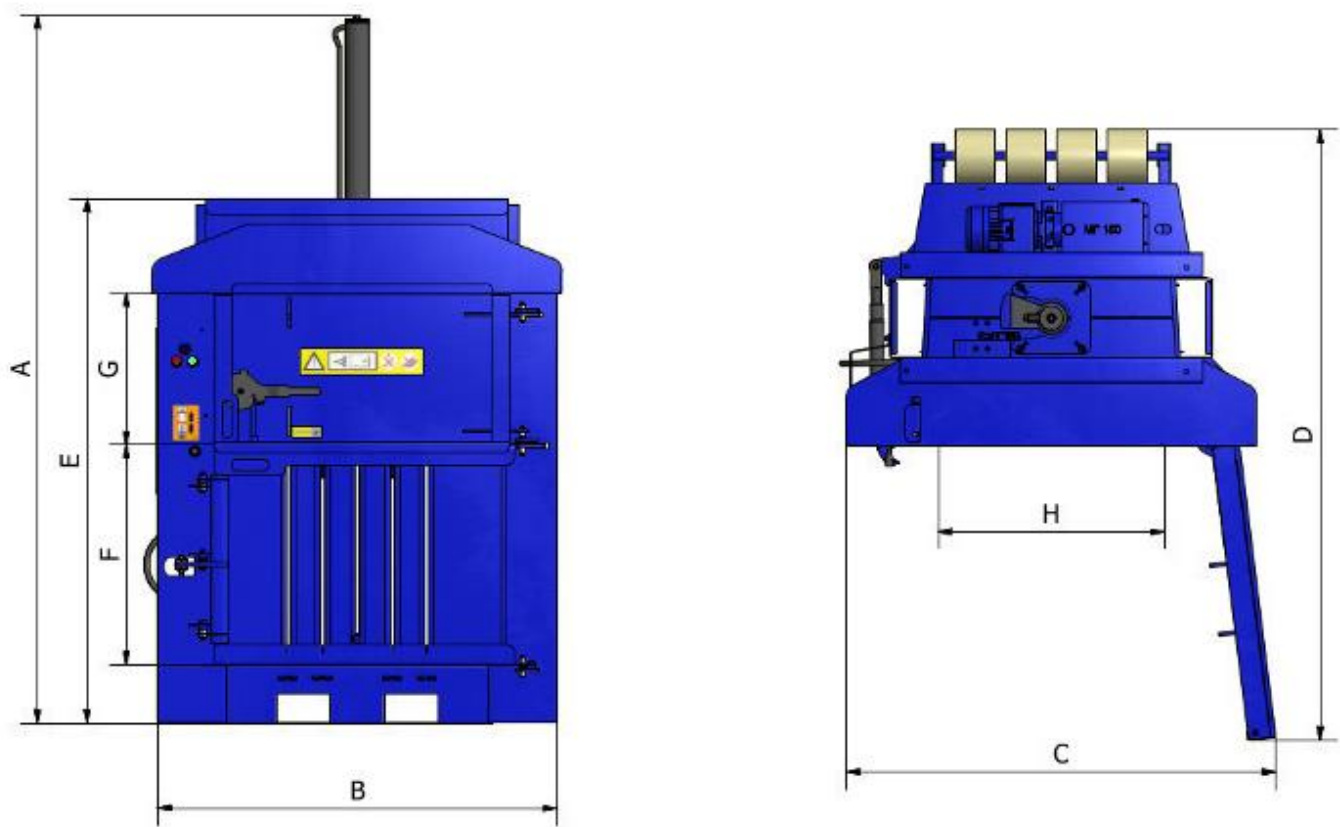

A 2.370 m

B 1.355 m

C 1.450 m

D 2.010 m

E 1.800 m

F 0.800 m

G 0.550 m

H 1.000 m