

FORKLIFT TIPPING BINS (LEVER RELEASE) MWFL SERIES SPECIFICATIONS

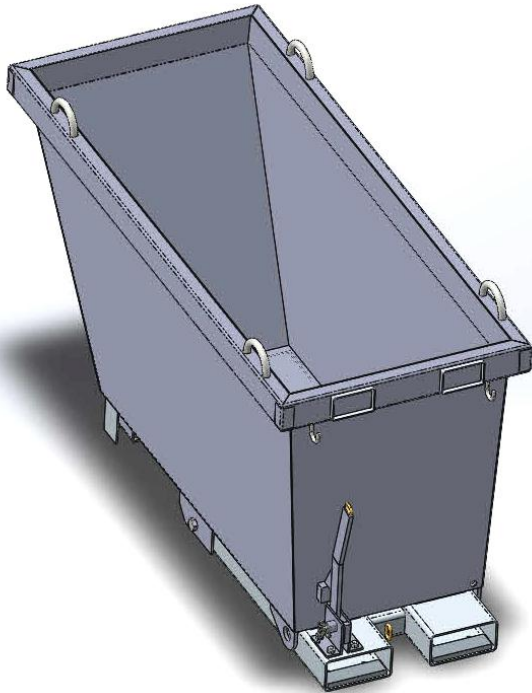

The type MWFL Tip-Up Bin has been manufactured from 3mm plate and designed with a low profile to allow versatility in confined spaces. The release mechanism is activated by the Forklift operator pulling the pull Cord from the driver's seat. The custom built shock absorber prevents impact forces being transmitted to the Forklift during emptying.

All type MWFL Bins has reinforced edging and a Catch Handle, and comes with 4 Crane Lugs. MWFL Bins have a Working Load Limit of 1500kg and range in sizes from 0.35 – 2.1 cubic metre capacities. The standard finish on the Bin is Galvanised.

SPECIFICATIONS:

- Working Load Limit: 1500kg
- Unit Weight – refer Table
- Volume Capacity – refer Table
- Horizontal C of G – refer Table
- Pocket size 185 x 70mm
- Pocket Centres – refer Table
- Wheels Optional
- Drain Valve & Strainer Optional

(Type MWFL74 standard model shown)

