

FORKLIFT MOUNTED WHEELIE BIN TIPPER MFWE24 SPECIFICATIONS

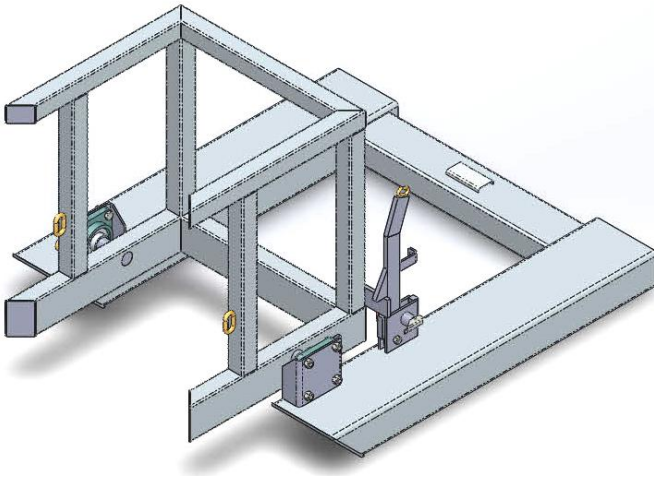

The type MFWE24 Wheelie Bin Tipper has been designed for emptying standard 240 litre plastic bins. The Bin is secured in the cradle by a Safety Chain allowing the bin to be lifted/ transported about the workplace and emptied. The tipping operation is simple and safe with the operator never having to leave his seat using a draw chord to activate the tipping action.

Standard finish on all Wheelie Bin Tippers is painted enamel, Colour: Mandarin X14

SPECIFICATIONS:

- Working Load Limit(WLL) 500kg
- Load Centre 1000mm
- Unit Weight 80kg
- Pocket Size 185 x 65
- Pocket Centres 840mm
- Capable of 180- degrees Rotation
- Horizontal C of G 650mm
- Vertical C of G 80mm

