

# FORKLIFT MOUNTED BULK BAG LIFTER MBBP2000 SPECIFICATIONS

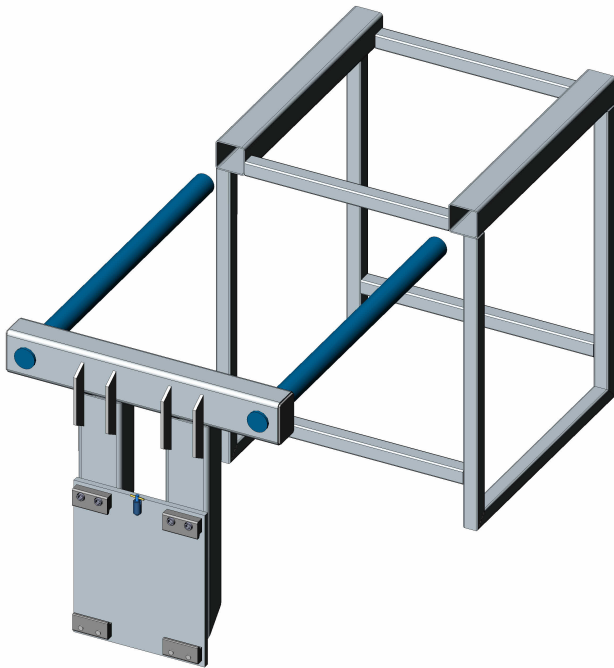

A two prong Class 2 Carriage mounted Bulk Bag Lifter for container loading. The Operator need not leave their seat to disengage the bag. Optional stand (shown) is available.

## SPECIFICATIONS:

- Safe Working Load (SWL): 2000 kg
- Unit Weight: 175 kg
- Load Centre: 600 mm
- HCG: 275 mm
- VCG: 660 mm
- Prong Height above Carriage: 436 mm
- Prong Centres: 800 mm
- Class 2 Mounting
- Refer Type BBP2000-C3 for Class 3 Mount

(Also available in Low Profile models)

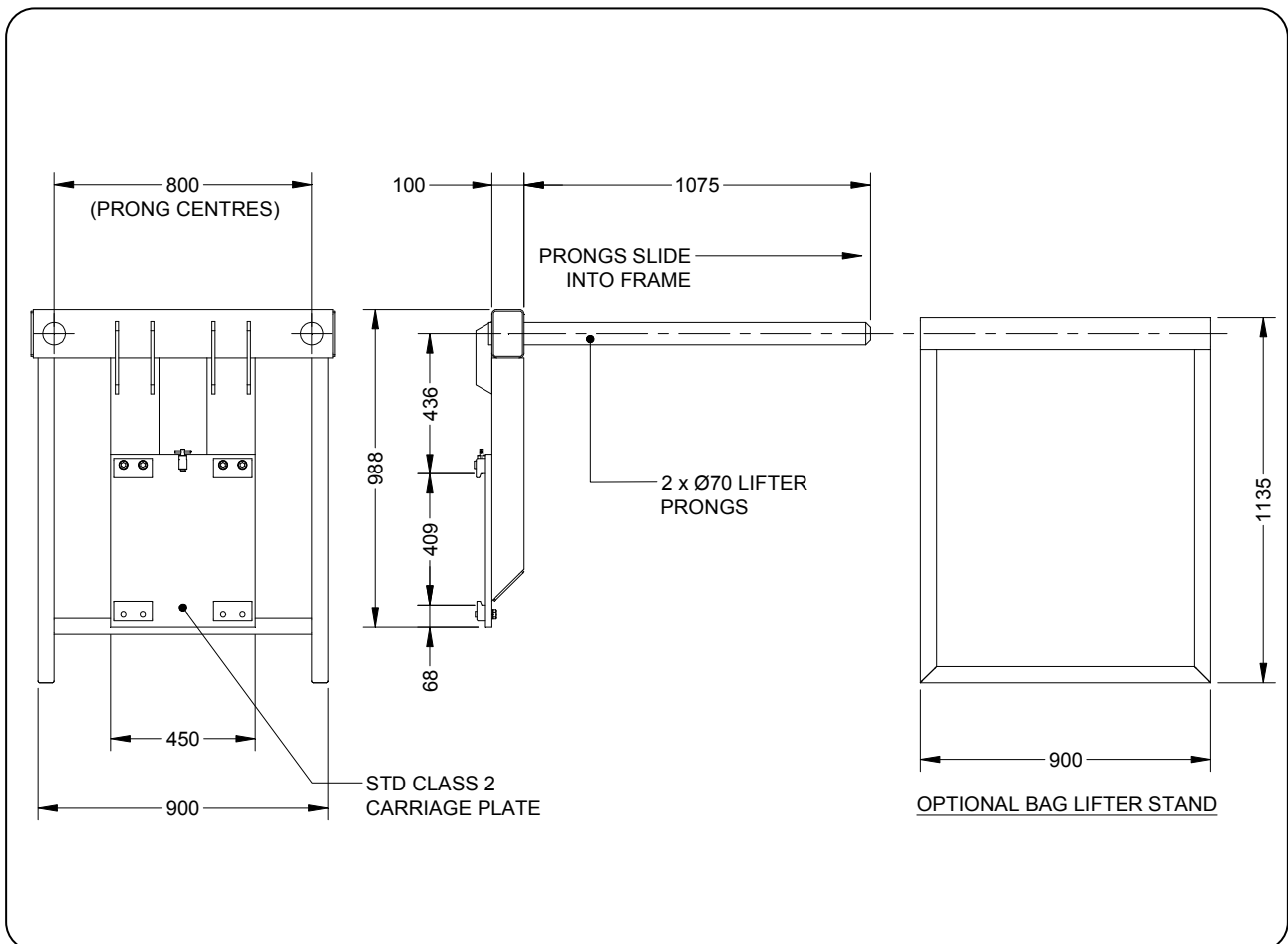

Australia Wide Sales & Service

sales@materialshandling.com.au | www.materialshandling.com.au | 1300 25 84 07

**MATERIALS**  
**Handling** PTY LTD *Working with ease.*