

CRANE SPREADER BEAMS LCSB SPECIFICATIONS

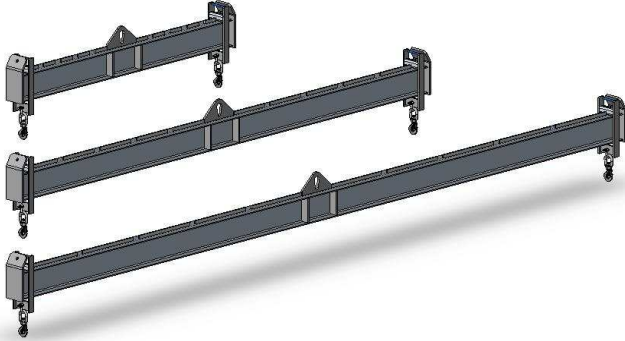

The type LCSB Crane Spreader Beams are available in a range of capacities and lengths to suit any application.

Crane Spreader Beams are supplied standard with 5 lift positions and fitted with 2 safety swivel hooks. The standard finish on all Crane Spreader Beams is painted enamel in 'safety yellow'.

The chart below shows the standard range of Crane Spreader Beams available. Choose the rating (Safe Working Load) and Beam length (Dimension 'A' value shown on the diagram below) to suit your application.

