

# HOPPER BINS MHB SPECIFICATIONS

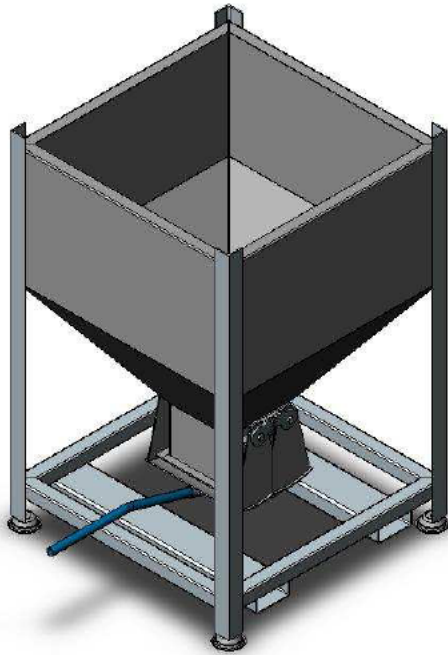

The type MHB1 Hopper Bins have been designed with a unique "Clam Shell" opening mechanism and are available in three models with different volume capacities as detailed in the table below. The bin has been fitted with Forklift pockets and is stackable (2 high) in its standard configuration.

The standard finish of the type MHB1 Hopper Bin is enamel painted over primed steel.

## SPECIFICATIONS:

- Pocket size 160 x 65 mm
- Pocket Centres – 625 mm
- Safe Working Load 1000 kg
- Unit Weight – refer Table
- Volume Capacity – refer Table
- HCG 600 mm
- Crane Lugs & Wheels Optional
- Lid Optional

(Standard type MHB110 model shown)

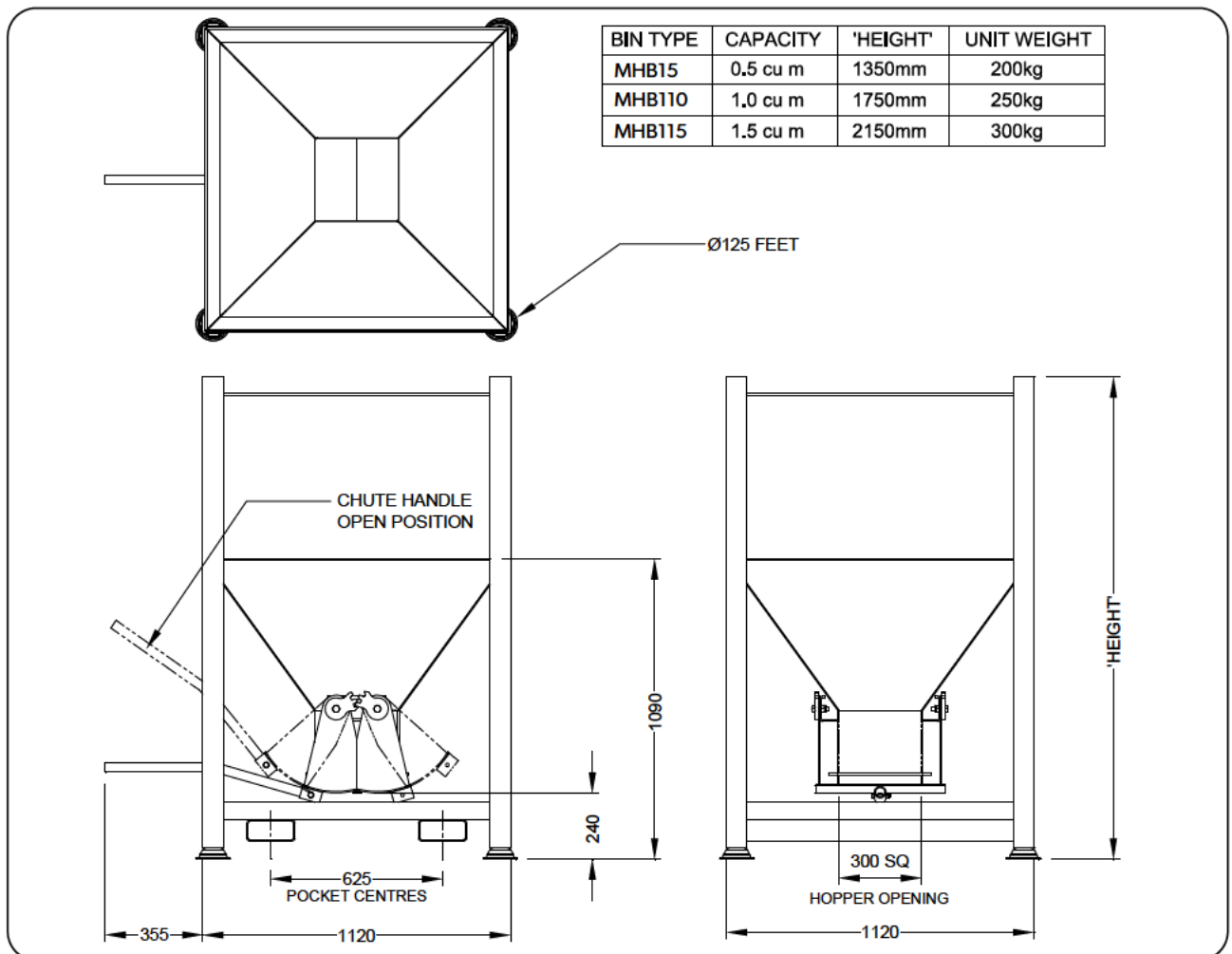

Australia Wide Sales & Service

sales@materialshandling.com.au | www.materialshandling.com.au | 1300 25 84 07

**MATERIALS**  
**Handling** PTY LTD Working with ease.