

FORWARD BIN TIPPER MFBTSM AND MFBTFH SPECIFICATIONS

The MFBT Hydraulic Forward Bulk Bin Tipper is designed for handling and emptying mega bins or similar bin types.

FEATURES:

- Allows handling and tipping of mega bins and timber produce bins - full or empty
- Suits bins up to 1200 mm square, with a height range of 700-900 mm
- MFBTSM model includes a hydraulic sequence valve reducing the risk of dropping the bin as rotation only commences after bin is clamped
- MFBTFH model is best suited for fast and high-volume tipping
- Wide clamp arms limit bin damage
- Slip-on attachment allows quick connection to a forklift
- Ideal for use in the fresh produce industry
- Enamel paint finish

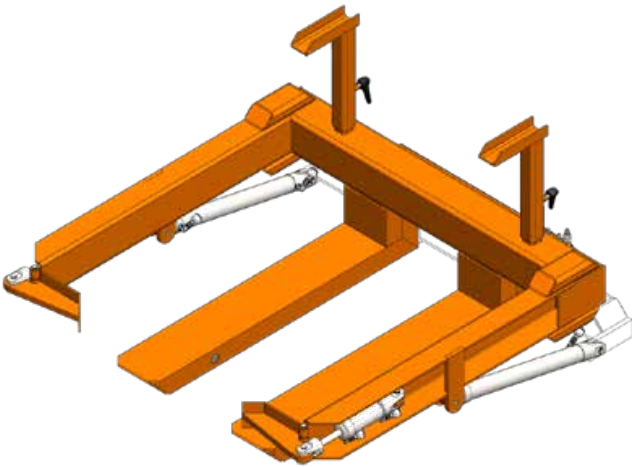

SPECIFICATIONS:

Working Load Limit (WLL)	1000 kg
Rotation Angle	124°
Unit Weight	350 kg
Fork Pocket Size	155 x 55 mm
Fork Pocket Centres	540 mm

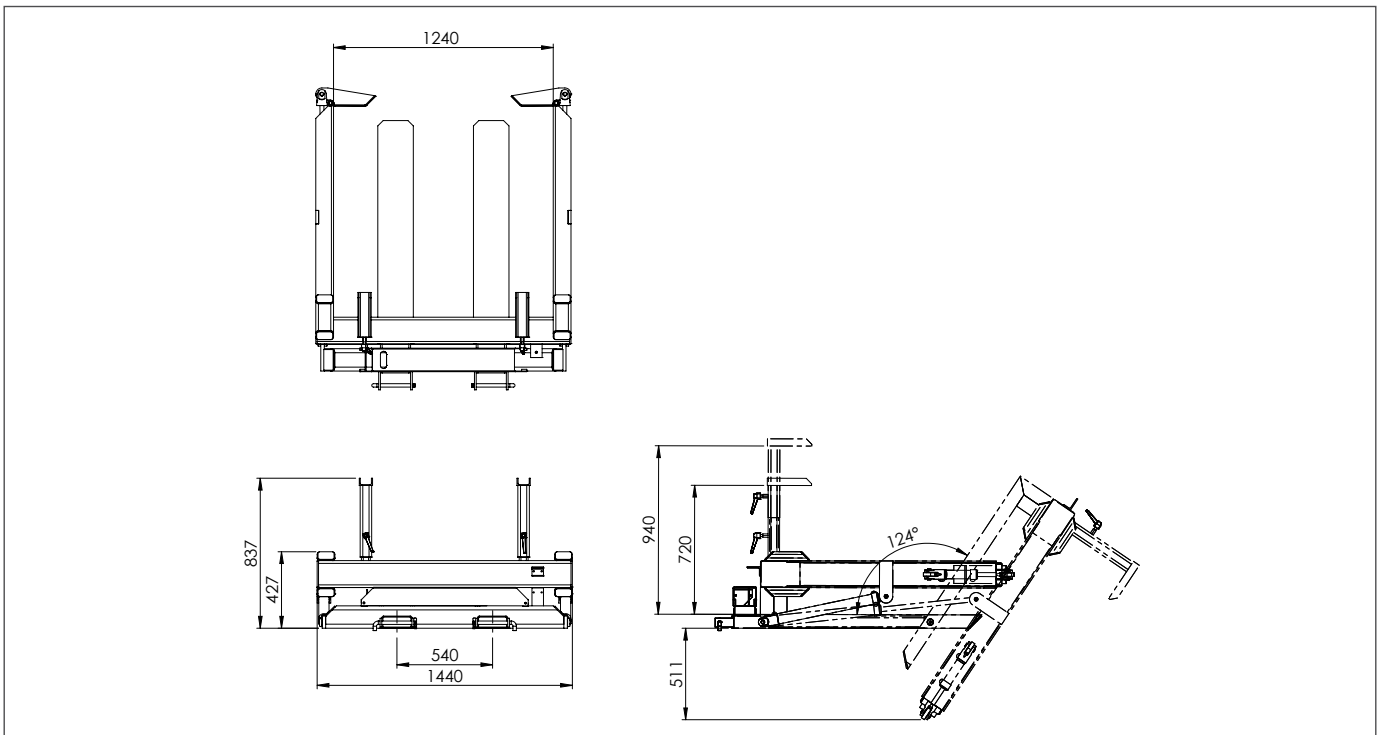

NOTE: MFBTSM requires one hydraulic function. MFBTFH requires two hydraulic function.

Australia Wide Sales & Service

sales@materialshandling.com.au | www.materialshandling.com.au | 1300 25 84 07

MATERIALS
Handling PTY LTD *Working with ease*