

FORKLIFT DRUM ROTATOR DDRNH SPECIFICATIONS

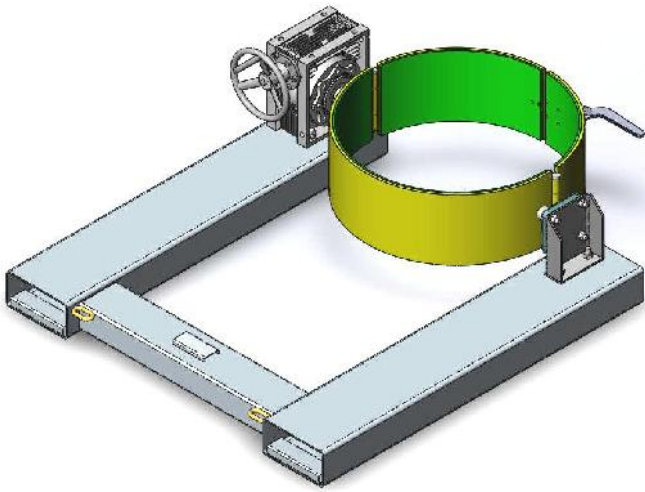

The type DDRNH Drum Rotator is designed to lift and rotate 205 litre Drums through 360-degrees. Handle rotation via a Gearbox, of the drum cradle, ensures minimum effort for fully controlled tipping. This allows a user to empty all the drum contents. A Belly Strap with an eccentric lock holds the Drum firmly in position.

This slip-on attachment requires only the connection of a safety chain to the Forklift. The standard finish of this unit is Zinc Plated.

SPECIFICATIONS:

- Working Load Limit (WLL) 400 kg
- Unit Weight 92 kg
- 360-degrees Rotation
- Load Centre 940 mm
- Pocket Size 185 x 60 mm
- Pocket Centres 840 mm
- Horizontal C of G 705 mm

