

DRUM CRUSHER MDC205 SPECIFICATIONS

Features

- Compaction ratio of 6:1
- Fully enclosed compaction chamber ensures maximum level of safety.
- 30 L oil collection tank with tap connection for easy drainage.

Optional Extras

- Adaptor head to compact inside 205 L drum
- Galvanised Finish
- Insert for crushing oil filters
- Smaller bale head inside to compact a 200 L steel drum

Specifications

Dimensions

Height	2 580 mm
Width	1 198 mm
Depth	927 mm
Weight	600 kg
Transportation Height	1 800 mm

Loading Aperture Sizes

Height	1 202 mm
Width	823 mm
Depth	816 mm

Performance

Power Supply	415V 3 Phase
Motor	11 kW 32A
Pressing Force	Up to 24T
Noise Level	74 dB
Cycle Time	57 Seconds

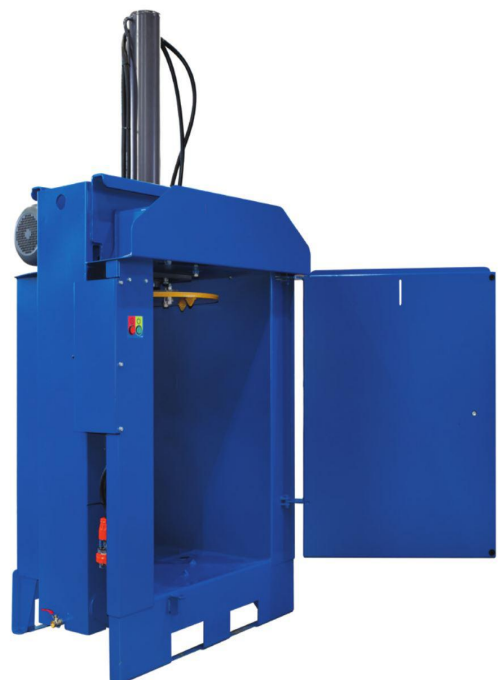

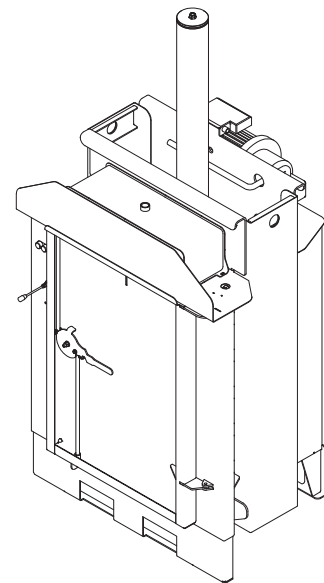
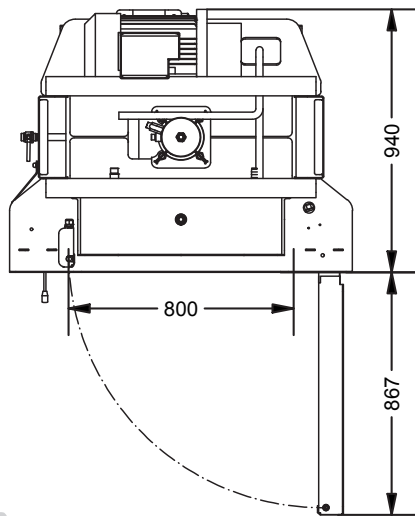
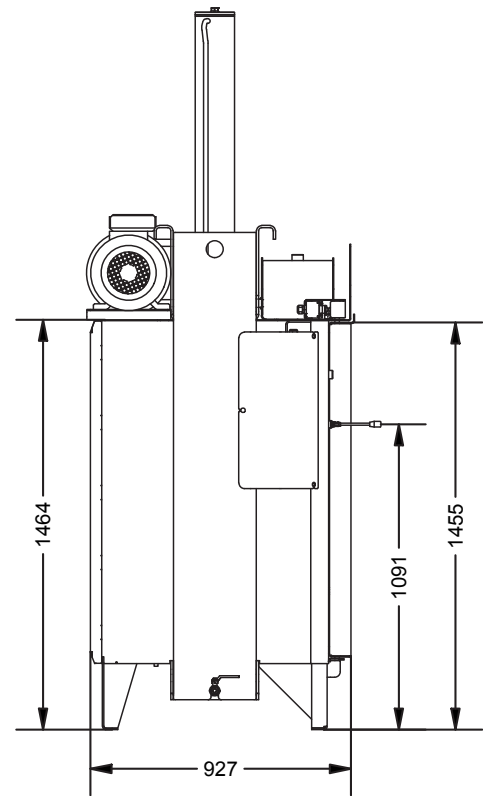
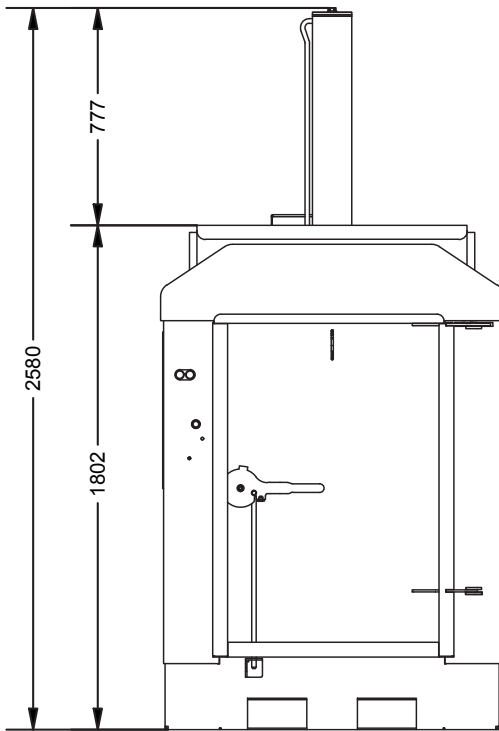

Dimensions and technical information without obligation. Subject to change.



Size Comparison



Compaction Ratio
Up to 6:1



Pressing Force
Up to 24 Ton

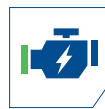

Motor
11kW



Waste Types
Metal Drums



Australia Wide Sales & Service
sales@materialshandling.com.au | www.materialshandling.com.au | 1300 25 84 07

MATERIALS
Handling *Working with ease.*
PTY LTD