

# DRUM LIFTER DDL1000PBO SPECIFICATIONS

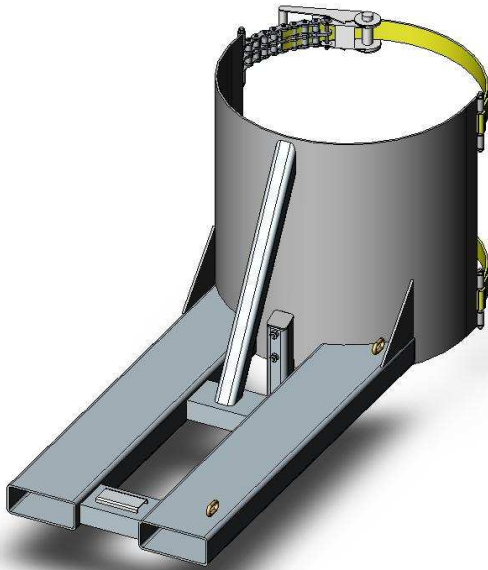

The type DDL1000PBO Drum Lifter would be considered the safest Drum Lifter available. This unit uses dual woven/chain combination belly straps with ratchet tightening to allow clamping of varying diameter drums, including standard plastic drums as well as barrels. With the added feature of a Bin Support Leg, drums/barrels may be moved with 100% security.

## SPECIFICATIONS:

- Safe Working Load (SWL) - 350kg
- Load Centre - 1160mm nominal
- Unit Weight - 75kg
- Pocket Size - 165 x 65mm
- Pocket Centres - 335mm
- HCG - 750mm
- VCG - 90mm

