

# CUBETAPE C190POS QUICKSTART GUIDE

## Contents

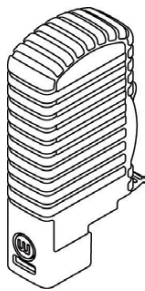

C190POS Cubetape

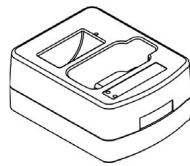

C190DSK Cradle

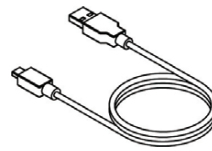

C190CRC USB Cable

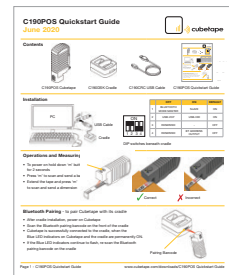

C190POS Quickstart Guide

## Installation

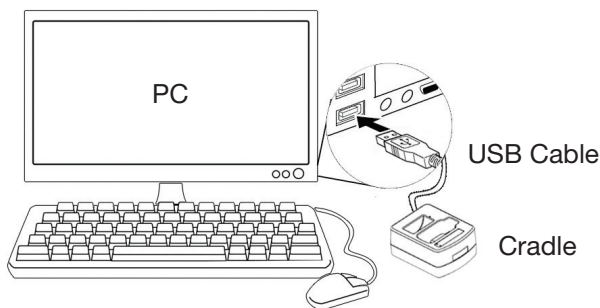

DIP switches beneath cradle

	OFF	ON	DEFAULT
1	BLUETOOTH MODE MASTER	SLAVE	ON
2	USB-VCP	USB-HID	ON
3	RESERVED	-	OFF
4	RESERVED	BT ADDRESS OUTPUT	OFF

## Operations and Measuring

- To power on hold down 'm' button for 2 seconds
- Press 'm' to scan and send a barcode
- Extend the tape and press 'm' to scan and send a dimension

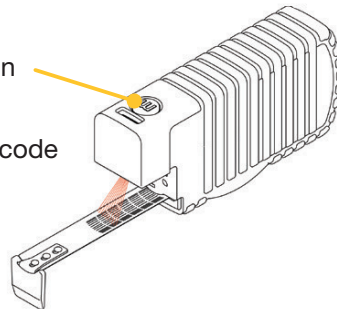

✓ Correct



✗ Incorrect

## Bluetooth Pairing - to pair Cubetape with its cradle

- After cradle installation, power on Cubetape
- Scan the Bluetooth pairing barcode on the front of the cradle
- Cubetape is successfully connected to the cradle, when the Blue LED indicators on Cubetape and the cradle are permanently ON.
- If the Blue LED indicators continue to flash, re-scan the Bluetooth pairing barcode on the cradle

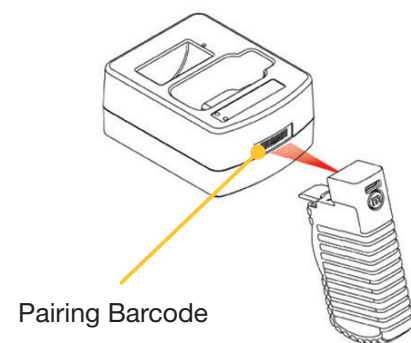

Pairing Barcode

# CUBETAPE C190POS QUICKSTART GUIDE

## Charging

- To charge battery place device in the cradle
- Battery is charging when device LED is red
- Battery is fully charged when device LED is green or off

### Device LED



**RED** Cubetape charging

**GREEN** Cubetape charged

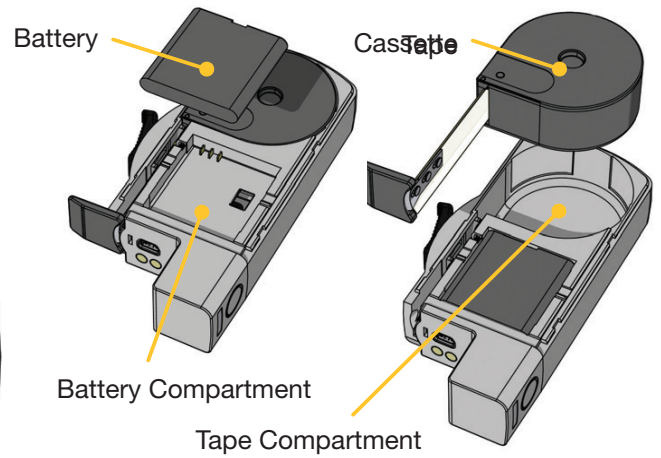
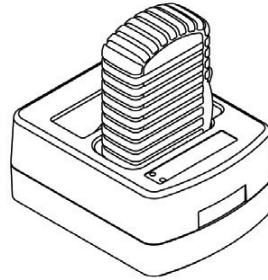

## General Settings

### Factory Defaults

Bluetooth Cradle Pairing Mode

Suffix TAB

Nearest whole inch

For more information, communication and configuration options please refer to the user guide at [www.cubetape.com/downloads](http://www.cubetape.com/downloads)

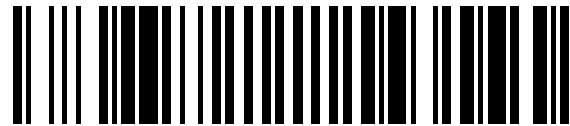

Default Factory Setting



Default Engine Setting

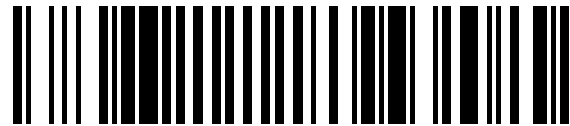

Bluetooth Reset

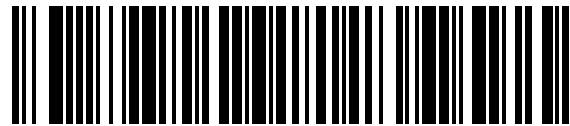

Suffix = TAB

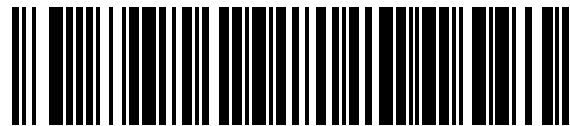

Suffix = CR