



1.2" LED display



Wireless Remote Control

# INDUSTRIAL SERIES

## Crane Scale

A rugged heavy-duty hanging scale for various industrial environments. The series is applicable in industrial areas including manufacturing factories and also heavy-duty industrial plants. Equipped with a wireless remote control function which makes operation more efficient and safe.

- Trade approved (NMI No. 6/13/4)



## SPECIFICATIONS

Model	L20THB	L30THB	L50THB
Max. Capacity (kg)	2,000	3,000	5,000
Readability (kg)	1	1	2
External Resolution	1/2,000	1/3,000	1/2,500
Display Digit	5 Digits		
Display Type	LED (1.2 inch)		
Operating Temp.	-10°C~40°C		
Power	DC 12V		
Dimensions (mm)	230(W) x 370(D) x 474(H)		230(W)x 370(D) x 518(H)
Product Weight (kg)	17		20

## FEATURES

- Standard wireless remote controller
- 2x Rechargeable battery packs & charger included
- Battery operated with low battery indication
- on/off, zero, tare, and hold function
- Easy-to-read 1.2" LED display
- Auto span adjustment & zero tracking

## DISPLAY & KEY PAD

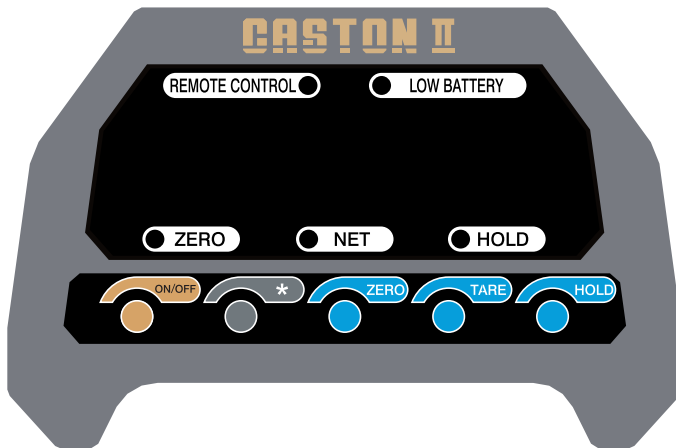

## DIMENSIONS

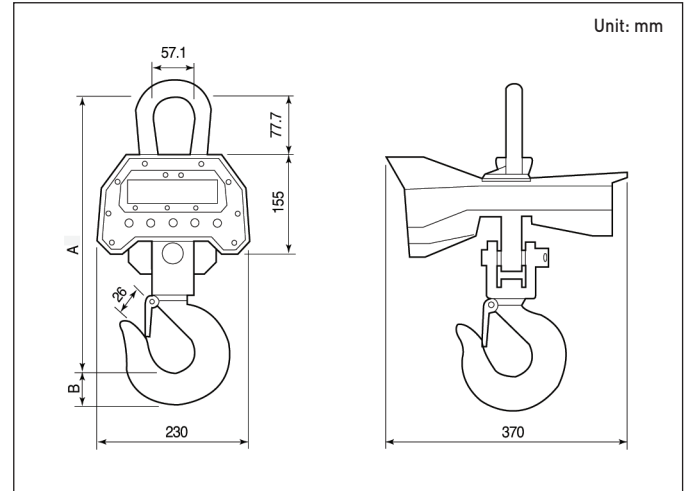

Model	Capacity	Gradustion	A	B	C	D	E	F
L20THB	2 ton	1 kg	430	57.1	91	47	45	30
L30THB	3 ton	1 kg	430	57.1	91	47	45	30
L50THB	5 ton	2 kg	474	57.1	100	47	45	30

Battery Pack  
Installation

