

# BULL-DOG DOWNPIPE PROTECTOR SPECIFICATIONS



**BDP100 Bull-dog Downpipe Protector**  
For downpipes up to 100 mm diameter

Features:

- Protects pipes and cables from vehicle damage.
- Clearly visible to reversing vehicles.
- Suitable for services up to 100 mm diameter.
- Robust 2.5 mm thick mild steel construction.
- 6 off 10 mm pre-drilled mounting holes.
- Easily retrofitted to existing services.
- Suitable for indoors or outdoors use.
- Hot dip galvanised with Yellow powder coat.
- 900 mm high for maximum protection.
- Total weight 7.8 kg.

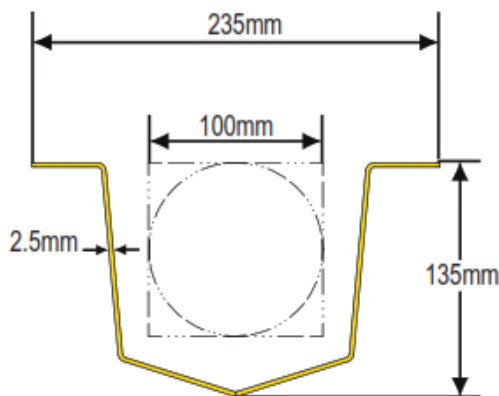

**BDP200 Bull-dog Downpipe Protector**  
For downpipes up to 200 mm diameter

Features:

- Protects pipes and cables from vehicle damage.
- Clearly visible to reversing vehicles.
- Suitable for services up to 200 mm diameter.
- Robust 3 mm thick mild steel construction.
- 6 off 10 mm pre-drilled mounting holes.
- Easily retrofitted to existing services.
- Suitable for indoors or outdoors use.
- Hot dip galvanised with Yellow powder coat.
- 900 mm high for maximum protection.
- Total weight 16 kg.

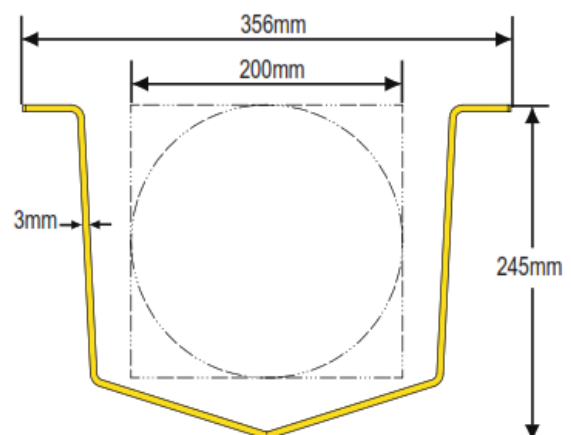

Australia Wide Sales & Service

sales@materialshandling.com.au | www.materialshandling.com.au | 1300 25 84 07

**MATERIALS**  
**Handling** PTY LTD Working with ease.