

BIN PRESS 660/1100 L SPECIFICATIONS



1100 L BIN PRESS FEATURES

- Reduces the frequency of daily/weekly bin collections.
- Base lifting plate ensures wheels are not damaged during compaction.
- Compaction ratio of 3:1.
- Two hand operation makes for a safer work environment.

OPTIONAL EXTRAS

- Adaptor available to compact 660 L bin.

BALER DIMENSIONS

Height	2.120 m
Width	1.160 m
Depth	1.150 m
Weight	270 kg
Power Supply	240V 1 Phase
Motor	1.5 kW
Pressing Force	Up to 3.5 T
Noise Level	72 dB
Cycle Time	20 Seconds

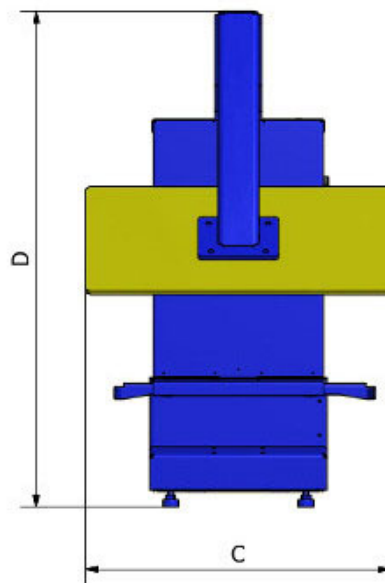
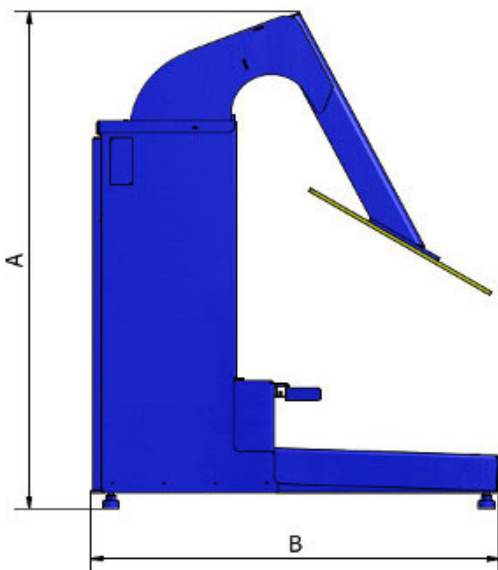

A 2.120 m

B 1.160 m

C 1.150 m

D 2.120 m

Australia Wide Sales & Service

sales@materialshandling.com.au | www.materialshandling.com.au | 1300 25 84 07

MATERIALS
Handling PTY LTD *Working with ease.*