

# CONTROL HANDLE WITH VACUUM GRIPPER

A tiltable end effector that, when integrated in Quick-Lift System, meets the highest standards of ergonomics, working environment, safety and efficiency.

Easy to use, thanks to outstanding responsiveness, regardless of load weight. Built in energy save function. Exceptional safety through built in warning function for insufficient vacuum, blow off and atmospheric pressure function.

High cost efficiency through high reliability and long durability. A strong solution for quick and easy handling.

The figures are to be seen as indications and will vary depending on lifting objects.

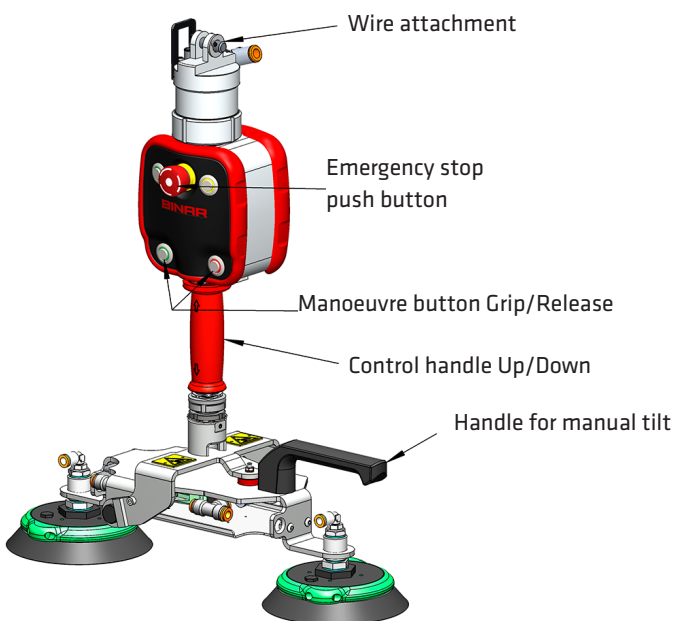
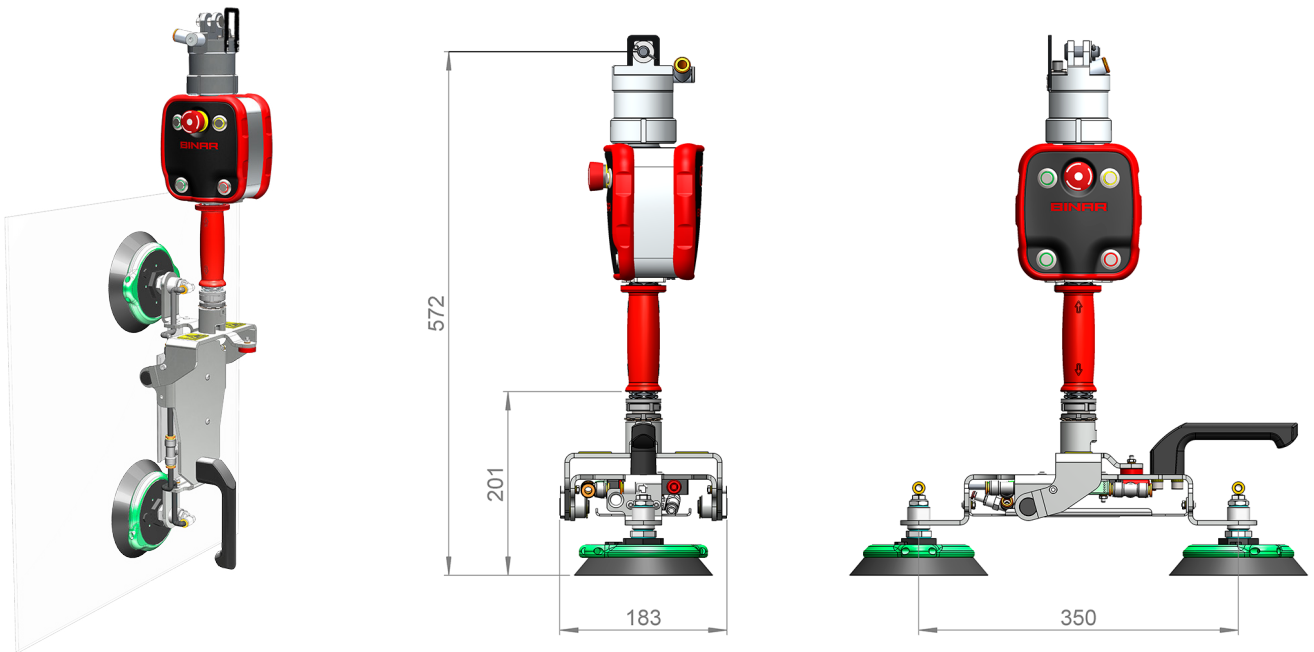

## TECHNICAL DATA

<b>Lifting Capacity</b>	For normal use on flat, dense and not greasy materials. Recommended vacuum level at 60 kPa. Maximum lifting capacity Horizontal: 85 kg Vertical: 60 kg
<b>Temperature</b>	For lifting objects 0-90°C
<b>End effcstors weight</b>	9 kg / 20 lbs
<b>Air supply</b>	Clean dry air, filtered, pressure 6-8 bar
<b>Safety</b>	2x safety has to be tested on each lifting object. Built in blow off function, atmospheric pressure function and warning for insufficient vacuum.

Binar Handling AB disclaims responsibility for any errors or incomplete information in the published material and reserves the right to make changes.

Australia Wide Sales & Service

sales@materialshandling.com.au | www.materialshandling.com.au | 1300 65 00 35

**MATERIALS**  
**Handling** PLY LTD Working with ease™