

LONG PRODUCT STILLAGE CAGE PLF4010 SPECIFICATIONS

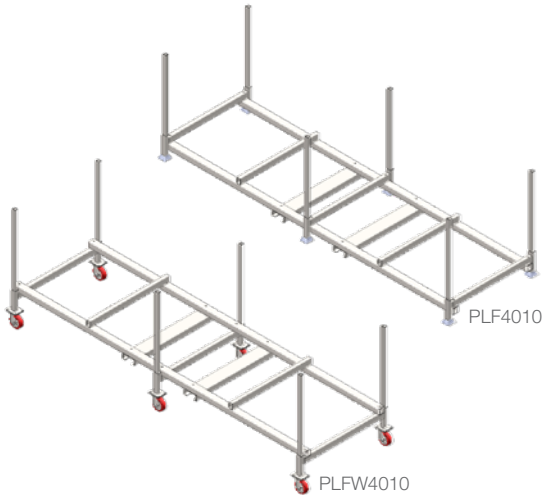

The PLF4010 Long Product Stillage is designed to safely store and transport long length materials such as pipe and conduit on site.

Features:

- Suitable to store and transport long materials such as pipe, conduit, timber etc
- Heavy duty construction for maximum stability
- Fork pockets fitted for safe transport around the workplace by forklift
- Model PLF4010 is stackable 2 high when fully loaded, 4 when empty
- Model PLFW4010 includes 150mm wheels & brakes for easy manoeuvring around the worksite
- Varying leg length available on request
- Also available in 4m long model PLF4010
- Zinc-plated finish

Model	Working Load Limit (kg)	Overall Length (mm)	Overall Width (mm)	Stackable	Wheels	Fork Pocket Size (mm)	Fork Pocket Centres (mm)	Unit Weight (kg)
PLF4010	1000	4040	1250	Yes	No	155 x 60	850	133
PLFW4010	1000	4075	1260	No	Yes	155 x 60	850	195

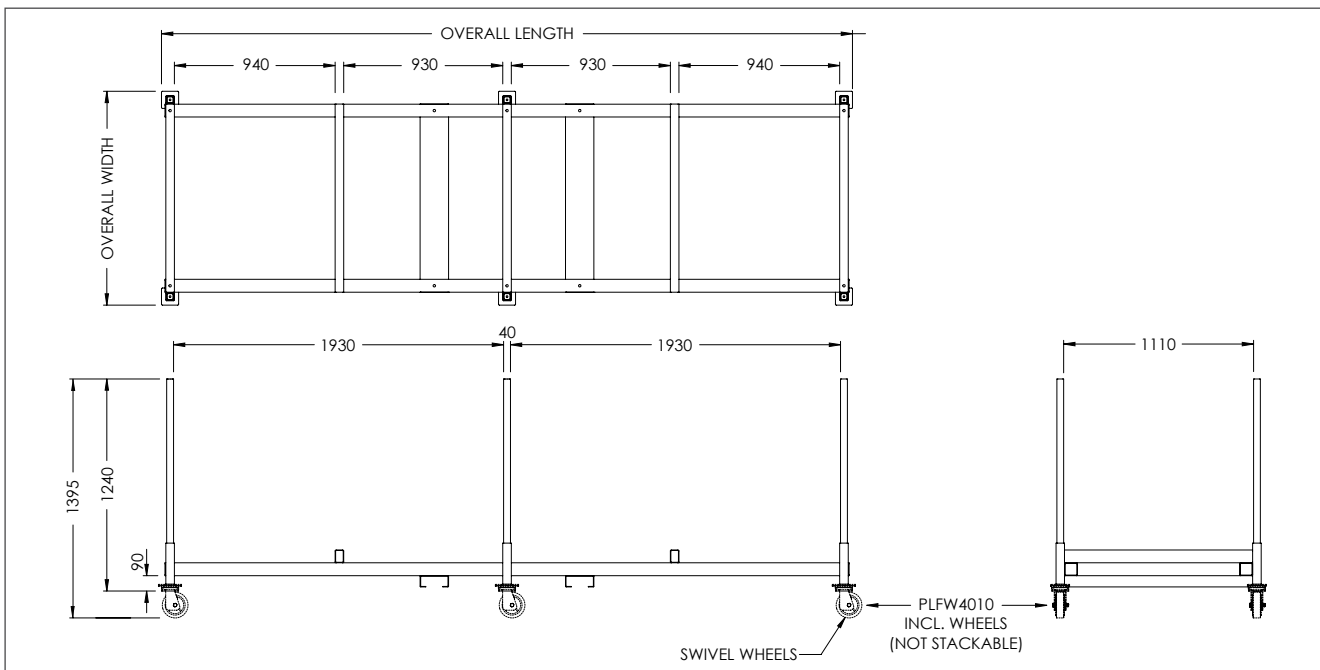

NOTE: Model supplied with wheels (PLFW4010) is **NON-STACKABLE**.
Due to transport requirements wheels are no longer pre-fitted on PLFW4010. Included wheel kits are supplied for fitment onsite, not pre-fitted.

Australia Wide Sales & Service

sales@materialshandling.com.au | www.materialshandling.com.au | 1300 25 84 07

MATERIALS
Handling PTY LTD Working with ease.