

GRAB ATTACHMENT MGA-09 SPECIFICATIONS

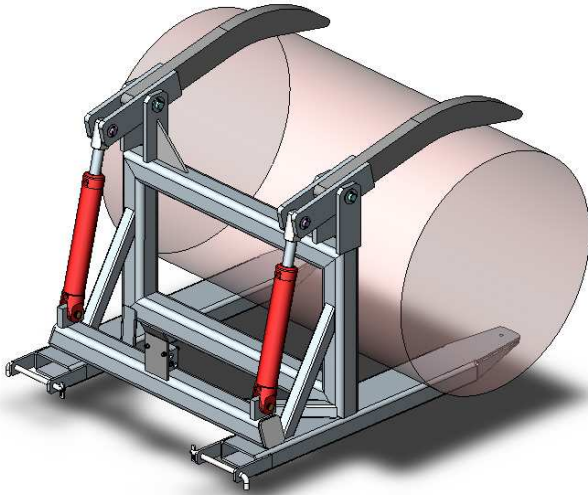

The type MGA-09 Grab Attachment has been designed to grab and secure poles or pipes from 170mm to 900mm in outside diameter and safely lift and transport these by Forklift about the worksite. This slip-on attachment can be fitted in seconds to a forklift requiring only the connection to the 3rd function hydraulics, via the quick connect hydraulic couplings, and the installation of two locking pins supplied to prevent the unit from moving off the fork arms.

The standard finish on this attachment is enamel painted over primed steel – colour: ' Safety Yellow'.

SPECIFICATIONS:

- Safe Working Load (SWL): 2500kg
- Load Centre: 950mm
- Unit Weight: 265kg
- Pocket Size: 165 x 60mm
- Pocket Centres: 931mm
- Minimum Pole Diameter: 170mm
- Maximum Pole Diameter: 900mm
- HCG: 420mm
- VCG: 300mm

