

LIFTING CLAMPS WITH WIDE OPENING TLC

Application

Lifting of horizontal plates or sheets (individual or in bundles), circular plates or fabricated assemblies. This product enables lifting thin or thick loads.

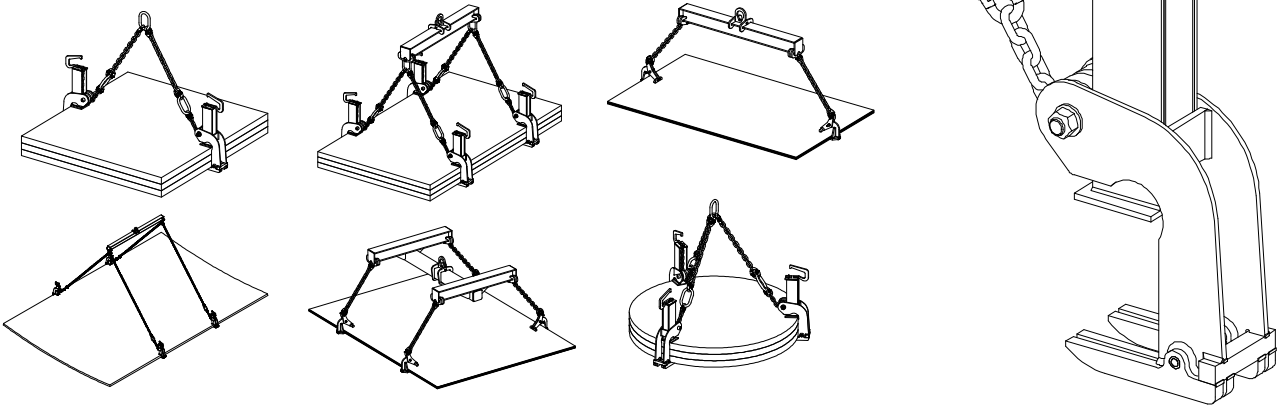

Accessories equipped with a slide ensuring clamping and automatic adjustment on the load. The handle makes the clamp's setting up easier. The clamping perpendicular to the load permits handling thin plates and minimize marking. Slings not provided.

Functioning

Use in pairs for lifting plates or sheets, individual or in bundles:

- 1 pair with a 2-legged sling
- several pairs with 2-legged slings and lifting beam.

Use in 3s with a 3-legged sling for lifting round plates.

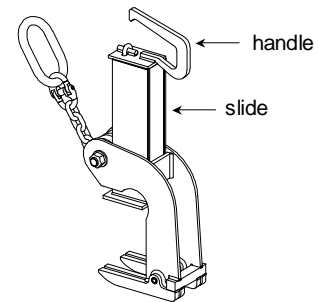

Fit the load into the clamps, making sure they are evenly distributed onto the piece to be lifted. The traction applied to the chain makes the slide go down, guided by the upright and the wheel, thus ensuring the closing of the clamp. Clamping is proportional to the load's weight, thus avoiding an excessive marking.

Important instructions

- The load must always be driven home into the throat of the clamp.
- The load must be rigid enough not to bend during handling operations.
- Adhere to the recommended sling angle: 45 to 90°.
- In case the sling angle be superior to 90°, use a clamp with a higher WLL according to the tension increase in the sling's leg.
- Line up the slings in the same plane as the clamps.
- Make sure the bearing plate and slide are nice and flat on top and under the load.
- Working temperature: -20° to +100°C.

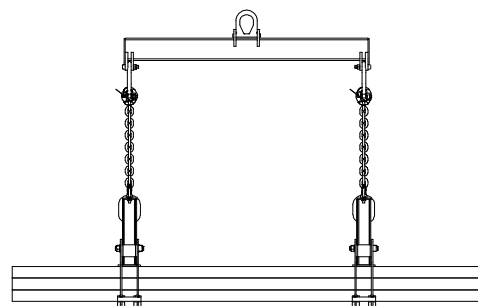
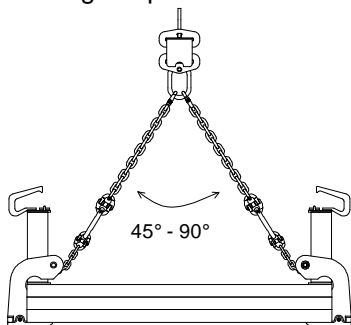

LIFTING CLAMPS WITH WIDE OPENING TLC

General characteristics

- Manufactured without load bearing welds.
- Hot epoxy coating.
- Safety factor: 3 in accordance with the EN 13155.2003 norm.
- Product conforms to the French regulation, in particular the decree of 01/03/2004 relating to the check on lifting devices and the European Directive n°2006/42/CE.
- Product with EC marking and delivered with a declaration of conformity and instructions for use.

Dimensional characteristics

Ref.	Group code	WLL/ pair kg	Opening		A	B	C	D	E	F		G	Sling angle		Chain* Ø	Ring Ø	Ring dim.	Weight/ pair kg
			min	max						min	max		min	max				
TLC1	50998	1 000	0	150	287	219	175	22	100	410	560	100	45°	90°	8	16	110 x 60	24
TLC2,5	51008	2 500	0	150	309	239	195	35	100	423	573	100	45°	90°	10	18	135 x 75	30
TLC4	51018	4 000	0	150	314	238	195	40	110	428	578	100	45°	90°	10	18	135 x 75	34
TLC6	51028	6 000	0	150	319	254	210	42	124	430	580	100	45°	90°	13	22	160 x 90	44

Dimensions in mm

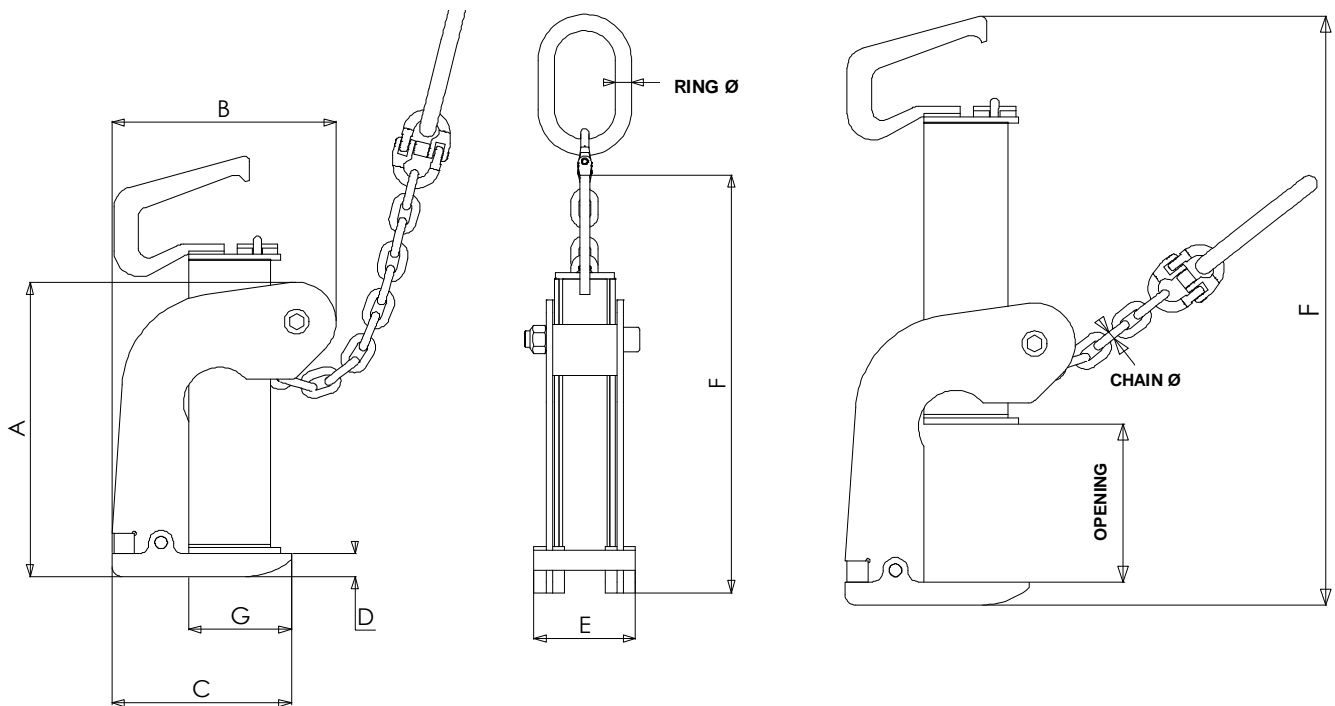

* provide a 2-legged sling grade 80 per pair of clamps

Practical information for sling definition

Plates width (mm)	800 to 1000	1000 to 1300	1300 to 1900	1900 to 3000	3000 to 5000
	Length of each chain leg (mm)				
TLC1	370	680	1070	1850	3300
TLC2	330	600	1000	1770	3200
TLC4	320	600	1000	1770	3200
TLC6	250	460	850	1640	3100