

# POWERED LIFTING HAND TRUCK LPS72 SPECIFICATIONS

INCREASE PRODUCTIVITY AND REDUCE JOB-RELATED INJURIES WITH THIS ALL-IN-ONE STACKER, TRANSPORTER, AND POSITIONER.

- Quick change adapter allows easy changes between attachments
- Up to 160 kg lifting capacity (54 kg on high-speed models)
- Lifts 50mm/second (100mm/second on high-speed models)
- Easy to operate; no certification required; see instructional video
- Supports diverse loading requirements
- Electric screw drive lift system provides smooth, quiet operation
- Narrow footprint fits through most doorways and tight spaces; no fork truck required
- Provides variable height work surface
- Minimizes bending and stretching

SPECIFICATIONS	
	72" Model
Attachment height (fully lifted)	1828 mm
Attachment height (fully lowered)	89 mm
Overall height	2133 mm
Overall depth	940 mm
Weight (base unit)	50 kg
High speed option	No
Battery capacity (median load)	125 lifts
Overall width (14" chassis)	N/A
Overall width (25" chassis)	838 mm
Chassis width	635 mm

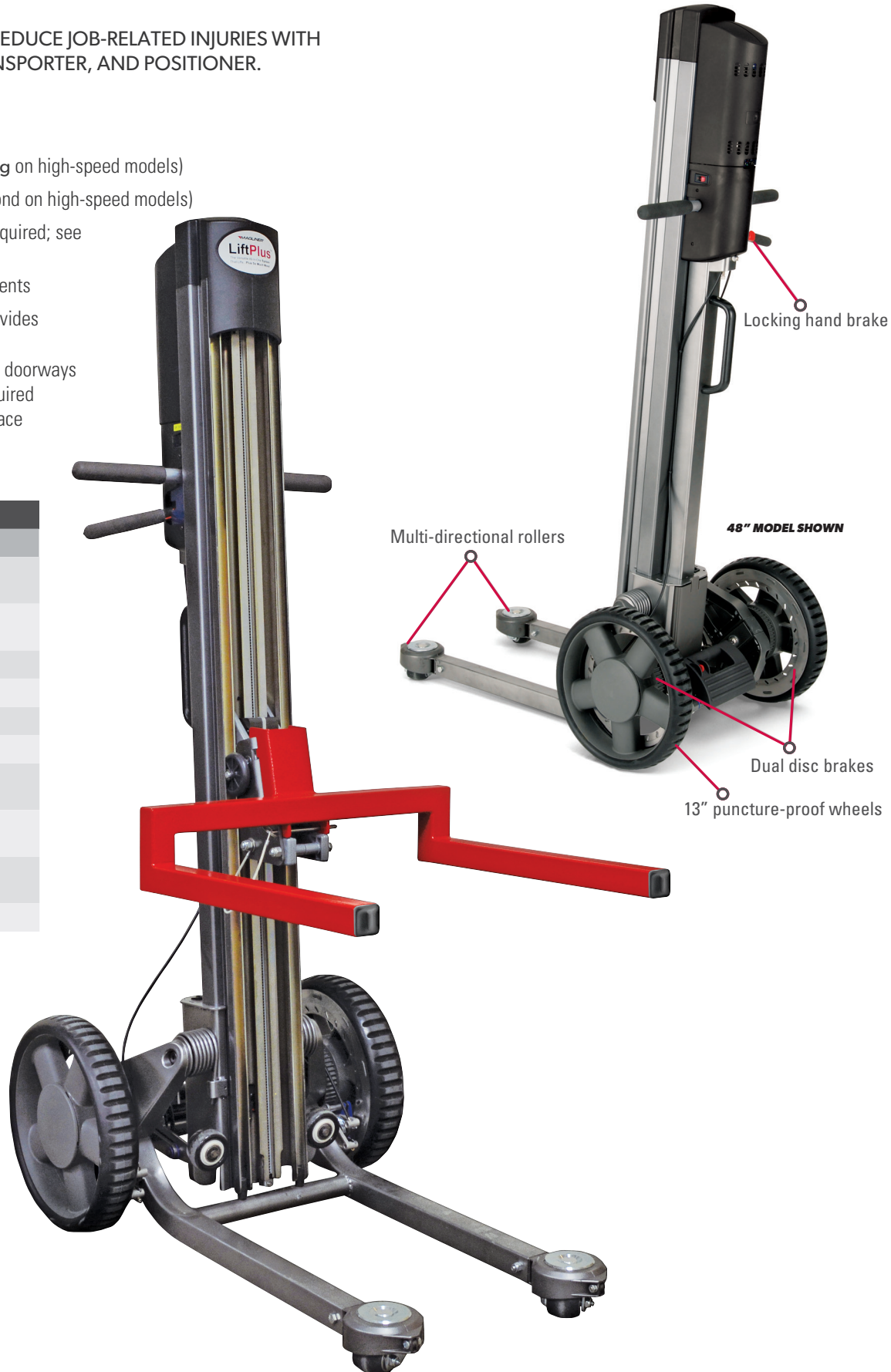



Australia Wide Sales & Service

sales@materialshandling.com.au | www.materialshandling.com.au | 1300 25 84 07

**MATERIALS**  
**Handling** *Working with ease.*  
PTY LTD