

GRAVITY ROLLER CONVEYORS SPECIFICATIONS

Gravity roller conveyors provide essential material handling free moving, efficient and safe transportation of goods at any operational stage of a conveyor line on a daily basis.

Gravity roller conveyors are an economical solution ideal for moving heavy and non standard shaped items along processing and packaging lines. Providing versatility with interlocking sections supplied as standard in 1.5 and 3 m lengths allowing for addition and of conveyor as required. Our conveyors have been designed with heavy duty channels, stronger cross members and a high quality powder coated finish for maximum rigidity.

It is recommended that there be a minimum of three rollers under the product to be transported at any one time. The size of the smallest object being transported can help determine the roller pitch on your conveyor system.

The steel channel is 30 mm wide x 80 mm tall with holes punched at 37.5mm centres. The conveyor frames can optionally be supplied with height adjustable support stands. Conveyor width typically refers to the overall width of the frame.

Choose from either galvanised steel (50 mm diam) rollers or plastic nylon (48 mm diam) rollers.

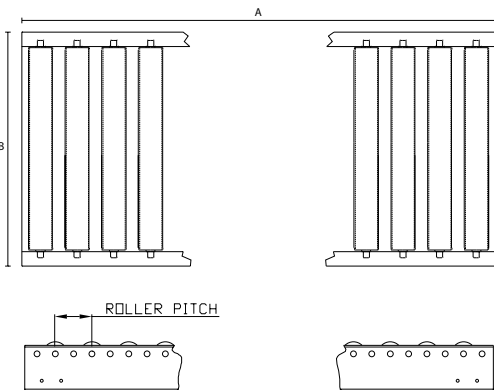

ROLLER SITS ABOVE CHANNEL
STEEL ROLLER 50MM DIAMETER
NYLON ROLLER 48MM DIAMETER

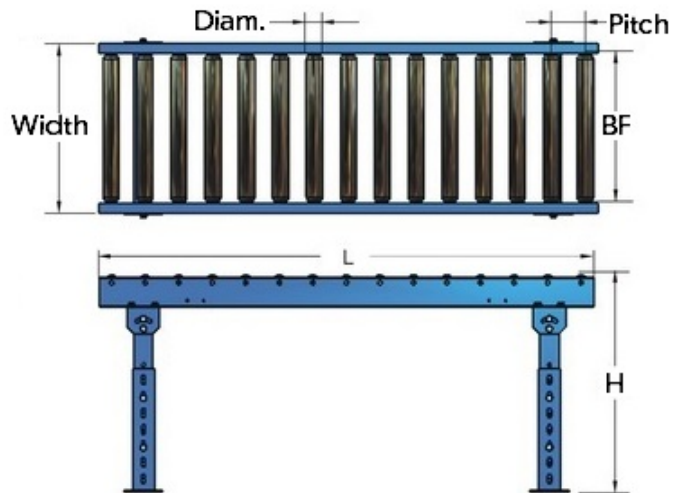
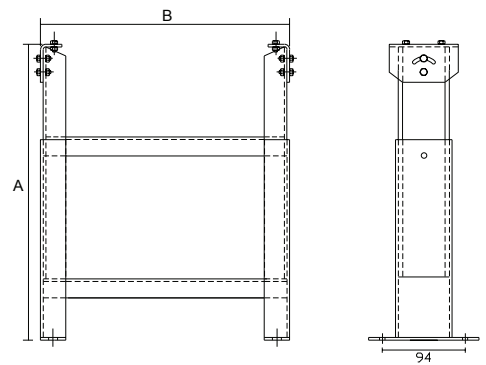

Australia Wide Sales & Service

sales@materialshandling.com.au | www.materialshandling.com.au | 1300 65 00 35

MATERIALS
Handling *Working with ease.*
PTY LTD

GRAVITY ROLLER CONVEYORS SPECIFICATIONS

Gravity roller conveyors can be extended with the addition of clever curve sections.

Gravity roller curves are ideal for moving items around 45 or 90 degree bends. Able to interlock with standard section lengths allowing for addition and of conveyor as required. Our conveyors have been designed with self-tracking rollers. Each shaft has two rollers to accommodate the product movement around the bend and eliminate the need for side-guides.

The conveyor frames can optionally be supplied with height adjustable support stands. It is recommended that each 45-degree section be supported at each end with a support stand. Each 90-degree section should have a stand at each end and in the middle.

Conveyor curves are only available with galvanised steel (50 mm diam) rollers with split shafts.

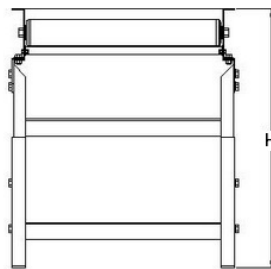
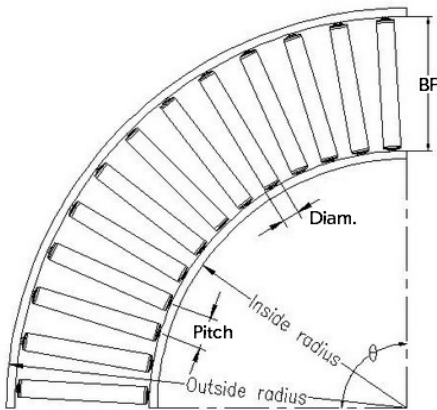
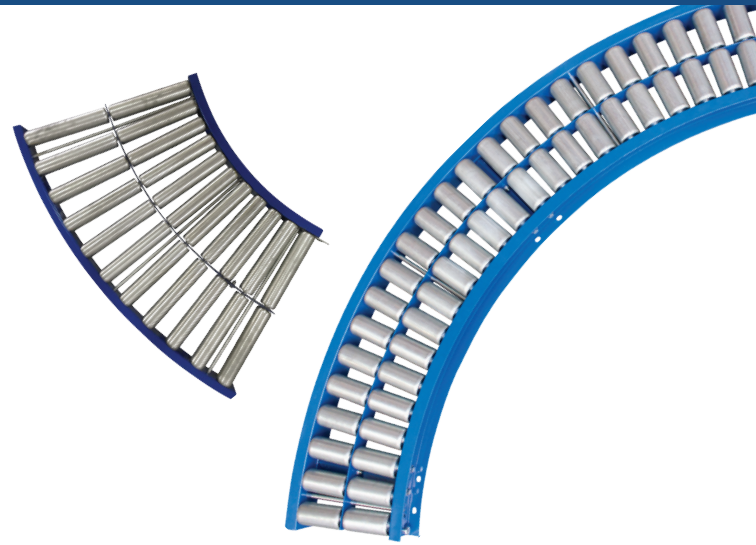

ROLLER SITS ABOVE CHANNEL
STEEL ROLLER 50MM DIAMETER

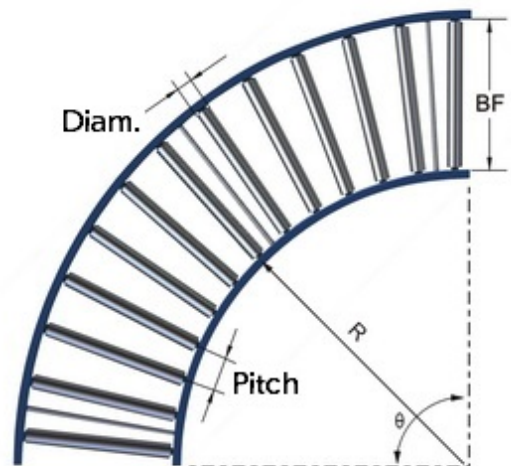

Australia Wide Sales & Service

sales@materialshandling.com.au | www.materialshandling.com.au | 1300 65 00 35

MATERIALS
Handling PTY LTD Working with ease.