

BULK BAG LIFTER FBC15 SPECIFICATIONS

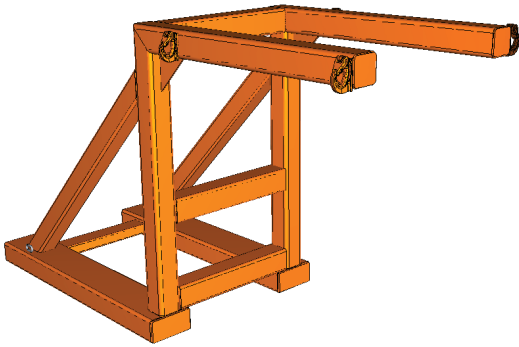

FBC15 Bulk Bag Lifter is designed for lifting, loading and transporting loaded bulk bags by forklift. Features:

- Allows bulk bags to be easily moved around the worksite or loaded into a container
- Bulk bag is secured via the four hooks on upper frame for safer handling
- Designed to maximise lift height
- Slip-on attachment and safety chain allows quick connection to a forklift
- Enamel paint finish



Working Load Limit (WLL)	1500kg
Load Centre	1800mm
Hook Centres	800mm
Unit Weight	179kg
Fork Pocket Size	185 x 65mm
Fork Pocket Centres	700mm
Horizontal C of G	993mm
Vertical C of G	444mm

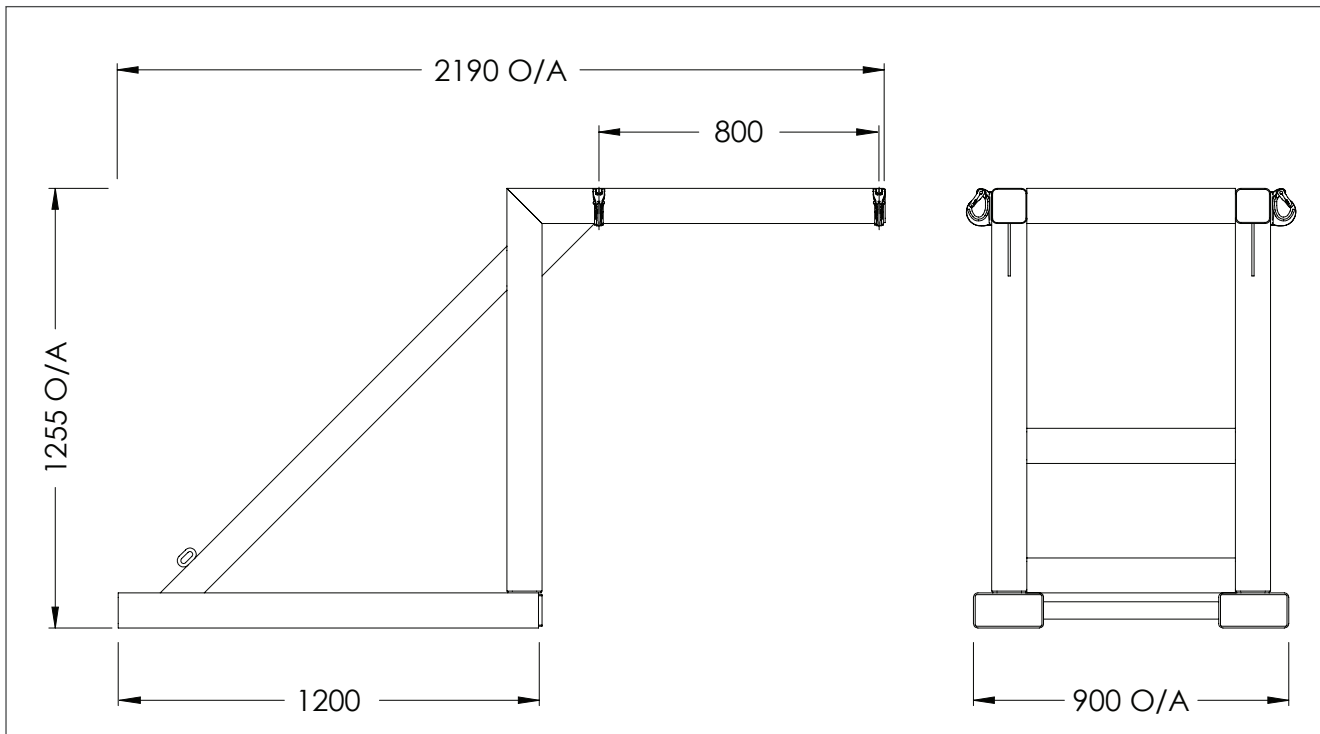

Australia Wide Sales & Service

sales@materialshandling.com.au | www.materialshandling.com.au | 1300 25 84 07

MATERIALS
Handling PTY LTD *Working with ease.*