

SUPPORT TRESTLE ATS SPECIFICATIONS



ATS Support Trestle is designed to safely support industrial loads around the workplace or construction site. These heavy duty steel units come in a range of sizes to suit various applications.

Features:

- Heavy duty steel construction for maximum load support
- Easy to assemble
- Optional rubber profiles (ATR120) available to help prevent load damage and movement. Up to 3 rubber channels can be fit across the width of a trestle
- Available in models with lockable wheels (ATSW) for mobility around the workshop
- Available in models with adjustable height (ATSJ)
- Available in models with adjustable height and lockable wheels (ATSJW) for complete flexibility
- Design & engineered to relevant Australian Standards
- Enamel paint finish

Supplied standard as flatpack (for on-site assembly)

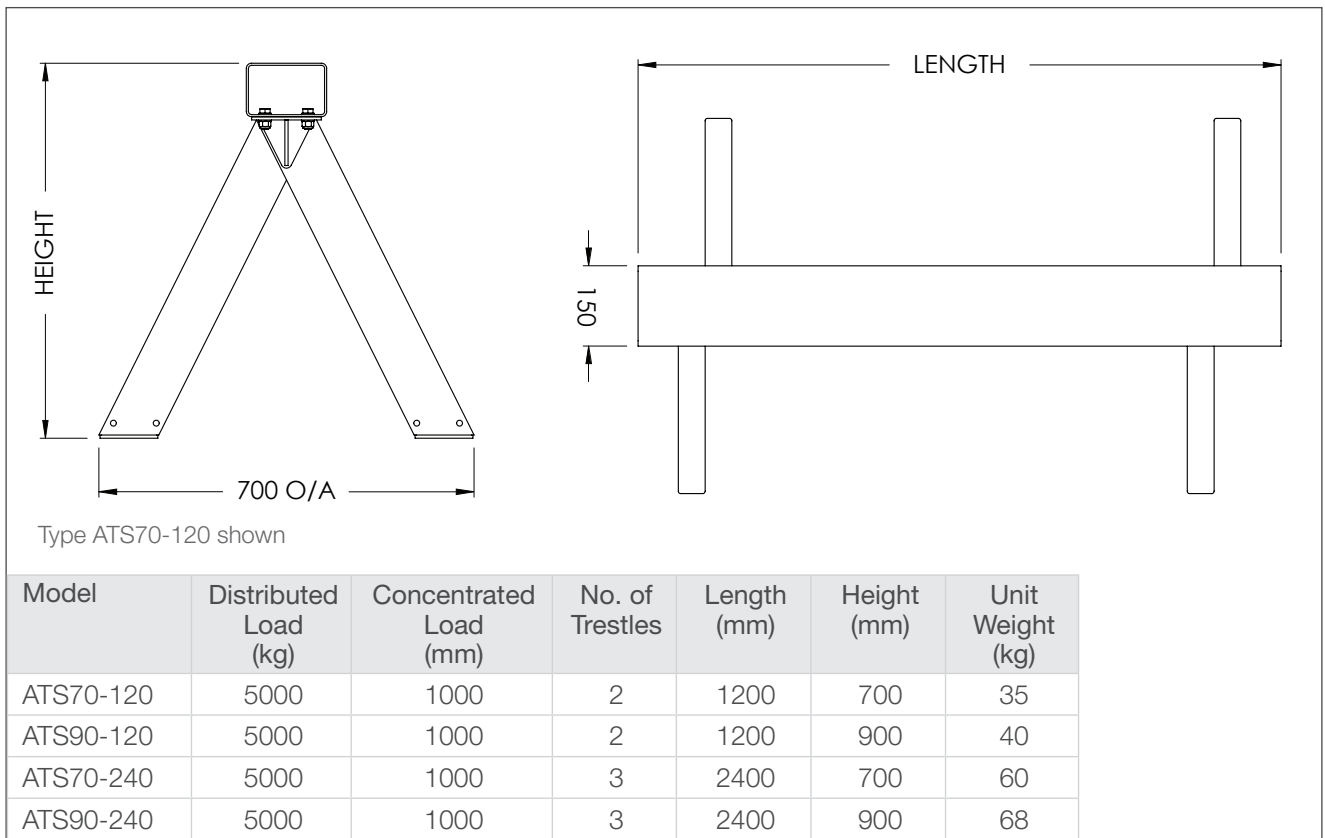

NOTE: Optional ATR120 Rubber profile channels are supplied in 1.2m lengths. 2 units required for 2.4m long trestles