

BULK BAG LIFTER MBBP2000 SPECIFICATIONS

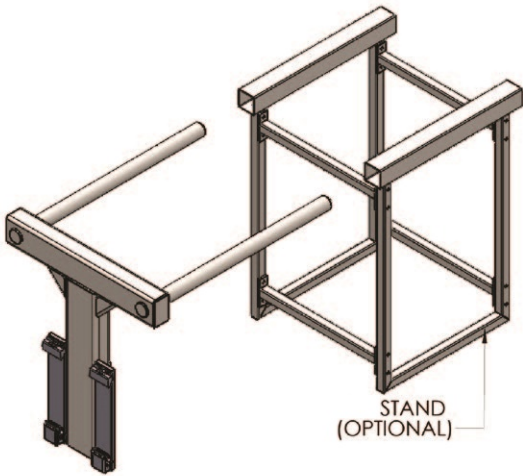

The MBBP2000 (QR) Bulk Bag Lifter with quick release bottom hooks for easy fitment is designed for lifting and moving loaded bulk bags by forklift.

Features:

- Allows bulk bags to be easily moved around the worksite or loaded into a container
- Two prong carriage mount jib simply slides into the lifting straps
- Operator can disengage the bulk bag without leaving their seat
- Spring loaded locators and quick release bottom hooks allow fast connection to a forklift
- Suits Class II or III forklift carriage types
- Optional jib stand MBBP2000S available for ease of storage and fitment of lifting jib
- Enamel paint finish

Model	Mounting Class	Working Load Limit (kg)	Load Centre (mm)	Prong Height Above Carriage (mm)	Prong Centres (mm)	O/All Dimensions W x L x H (mm)	HCG (mm)	VCG (mm)	Unit Weight (kg)
MBBP2000	Class 2	2000	600	492	800	940 x 1205 x 1055	305	265	150
MBBP2000QR3	Class 3	2000	600	503	800	940 x 1213 x 1175	285	215	165

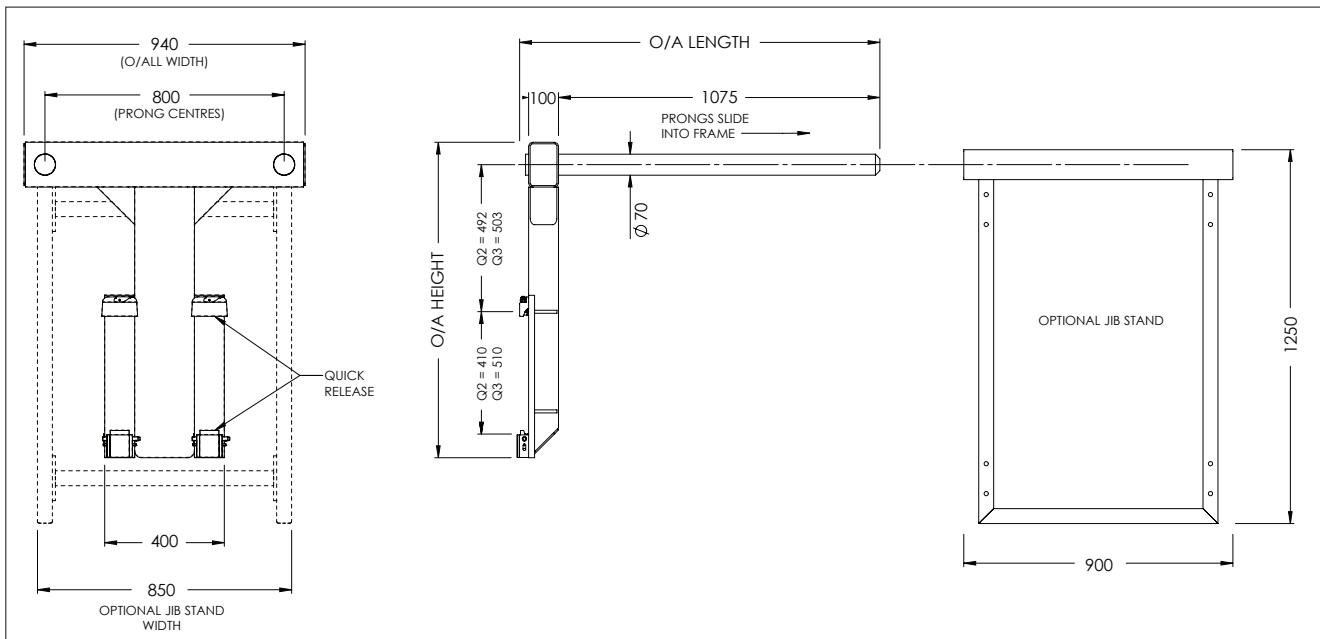

Australia Wide Sales & Service

sales@materialshandling.com.au | www.materialshandling.com.au | 1300 25 84 07

MATERIALS
Handling PTY LTD Working with ease.