

# ROLL DISPENSER LIFTING BEAM

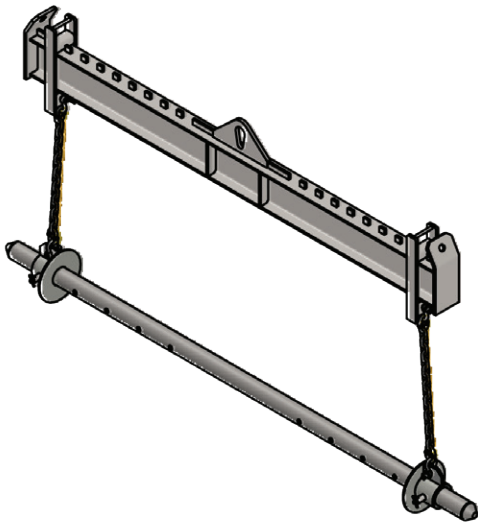

The RDB2X2 Roll Dispenser Beam is a spreader beam designed to safely lift and lay rolls and liners such as those used in ground preparation work in construction, landscaping and farming applications. This unit improves operational productivity and reduces manual handling of long, heavy rolls during installation.

## Features:

- Suitable for dispensing rolled materials such as geotextiles
- 5 adjustable lift positions on each end
- Beam to spindle link chains supplied
- Customised units to suit application available on request
- Enamel paint finish

Working Load Limit (WLL)	2000kg
Roll Width	600 - 2000mm
Maximum Roll Diameter	1500mm
Minimum Roll Hole Diameter	80mm
Axle Weight	29kg
Unit Weight	110kg

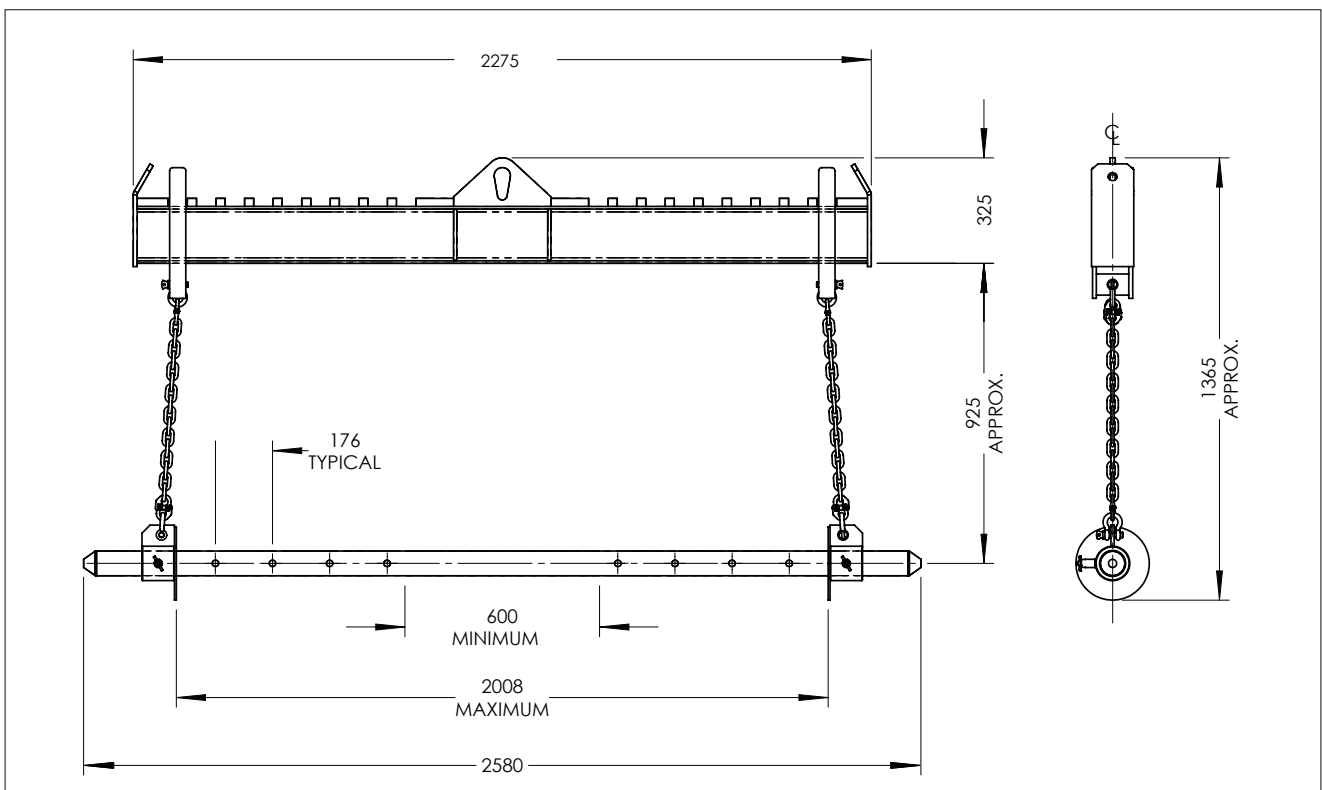

Australia Wide Sales & Service

sales@materialshandling.com.au | www.materialshandling.com.au | 1300 65 00 35

**MATERIALS**  
**Handling** *Working with ease*  
PTY LTD