

ROLL DISPENSER LIFTING BEAM

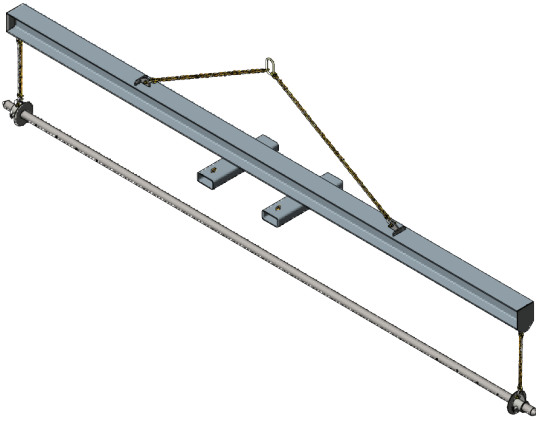

The RDB1X6 Roll Dispenser Beam is a spreader beam designed to safely lift and lay rolls and liners such as those used in ground preparation work in construction, landscaping and farming applications. This unit improves operational productivity and reduces manual handling of long, heavy rolls during installation.

Features:

- Suitable for dispensing rolled materials such as geotextiles
- 5 adjustable lift positions on each end to suit 4-6m rolls
- Beam to spindle link chains supplied
- 2 leg chain sling supplied standard
- Fork pockets fitted
- Customised units to suit application available on request
- Enamel paint finish



Working Load Limit (WLL)	1250kg
Roll Width	4000 - 6000mm
Maximum Roll Diameter	1500mm
Minimum Roll Hole Diameter	80mm
Axle Weight	70kg
Unit Weight	460kg
Fork Pocket Size	180 x 80mm
Fork Pocket Centres	800mm
Horizontal C of G	400mm
Vertical C of G	-70mm

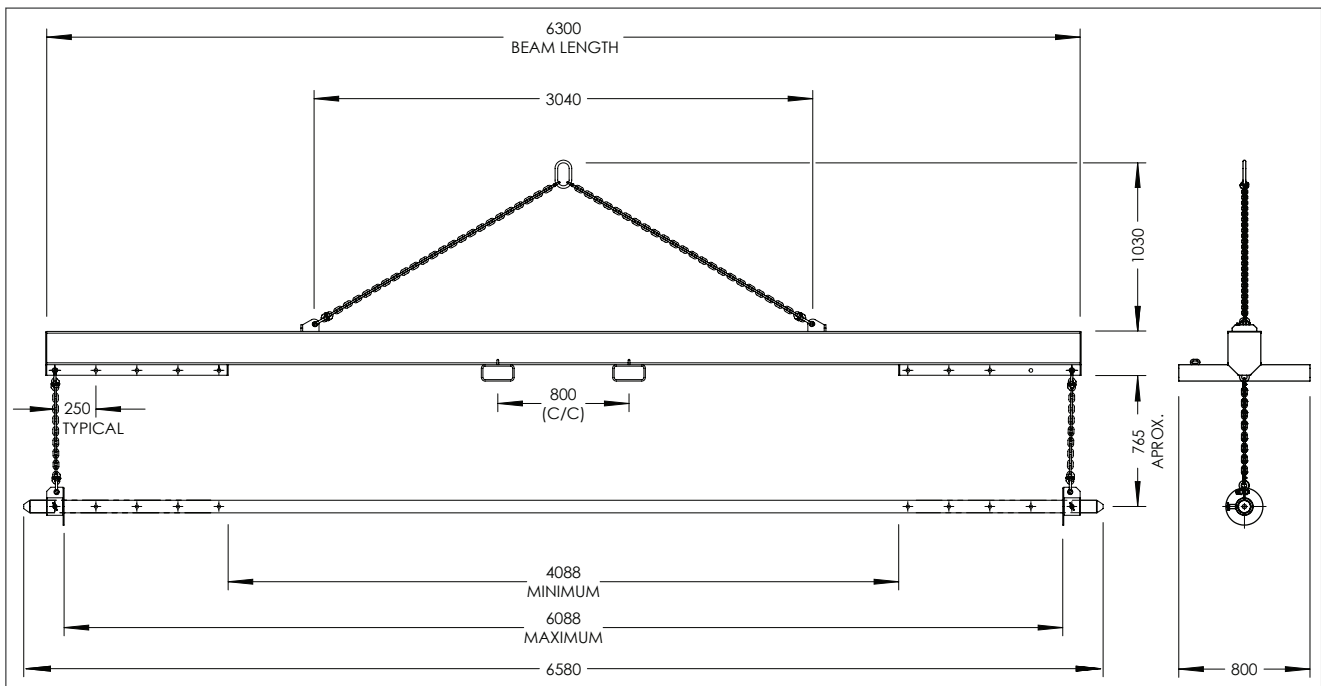

Australia Wide Sales & Service

sales@materialshandling.com.au | www.materialshandling.com.au | 1300 65 00 35

MATERIALS
Handling *Working with ease.*
PTY LTD