

# Working with ease...

## PRORUNNER® Mk1: reliable and affordable vertical conveyor

The PRORUNNER® Mk1 is a solid vertical conveyor which does what it has to do day in day out and year in year out, that is to say lifting and lowering products without you having to bother about it. It offers the perfect solution for capacities of up to a maximum of 650 products/hour. Because of its extremely small footprint, this lift can fit into almost any layout. The compact unit is very easy to incorporate into your transport system and can be fitted with a roller conveyor or a conveyor belt as you see fit. On account of its design which makes use of extremely reliable components, the machine requires hardly any maintenance. In a nutshell, it is a product lift which is easy to incorporate into your business and which continues to be available at an affordable price.



**MATERIALS**  
**Handling** *Working with ease...*  
PTY LTD

Our website: [www.materialshandling.com.au](http://www.materialshandling.com.au)  
Phone us: 1300 25 84 07 Fax us: 1800 68 68 96  
Email us: [sales@materialshandling.com.au](mailto:sales@materialshandling.com.au)

**Australia Wide Sales and Service**

## Advantages of the PRORUNNER® Mk1

- Minimum footprint
- Suitable for vertical sorting (several heights)
- Right-angle arrangement also possible
- Boxes, crates and sacks up to 100 kg
- No more lubricating or tightening of chains
- Steel and thus solid construction
- Robust and low maintenance
- Low noise



Tech Specs		Standard	Optional up to
Infeed	mm.	670	420
Outfeed	mm.	2.900	11.400
Capacity	p/hour.	450	650
Product	L x W mm.	600 x 400	1200 x 600
Weight	Kg.	50	100



11,4 m

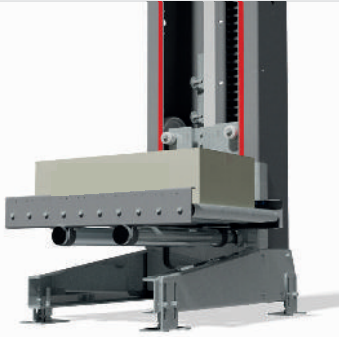
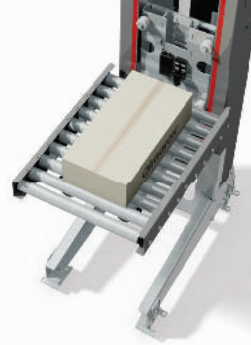

100 Kg

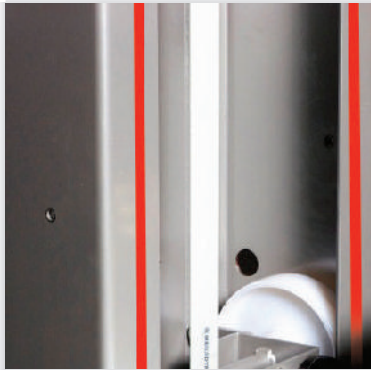

650 / h

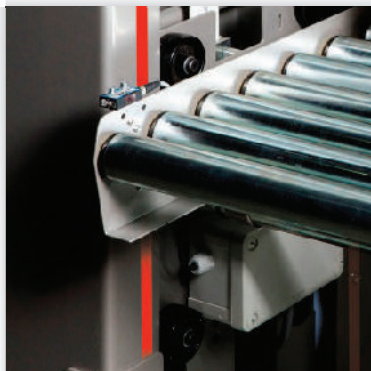

0.7 m<sup>2</sup>



Customer: \_\_\_\_\_

E-mail: \_\_\_\_\_

Product: \_\_\_\_\_

Product sizes: ..... x ..... x ..... mm.

Capacity: min. .... p/min. max. .... p/min.

Product weight: min. .... Kg. max. .... Kg.

Product orientation infeed: Short / Long Side Leading

Product orientation outfeed: Short / Long Side Leading

Product infeed: ..... mm.

Product outfeed: ..... mm.

Infeed conveyor: Driven / Gravity

Outfeed conveyor: Driven / Gravity

Field components included: Yes / No

Safety fencing included: Yes / No

Safety fencing door included: Yes / No

Operational: ..... / ..... | ..... / .....  
 Hour / Day Days / Week

Lay-out: Send to [sales@materialshandling.com.au](mailto:sales@materialshandling.com.au)

Environment conditions: \_\_\_\_\_

Special remarks: \_\_\_\_\_

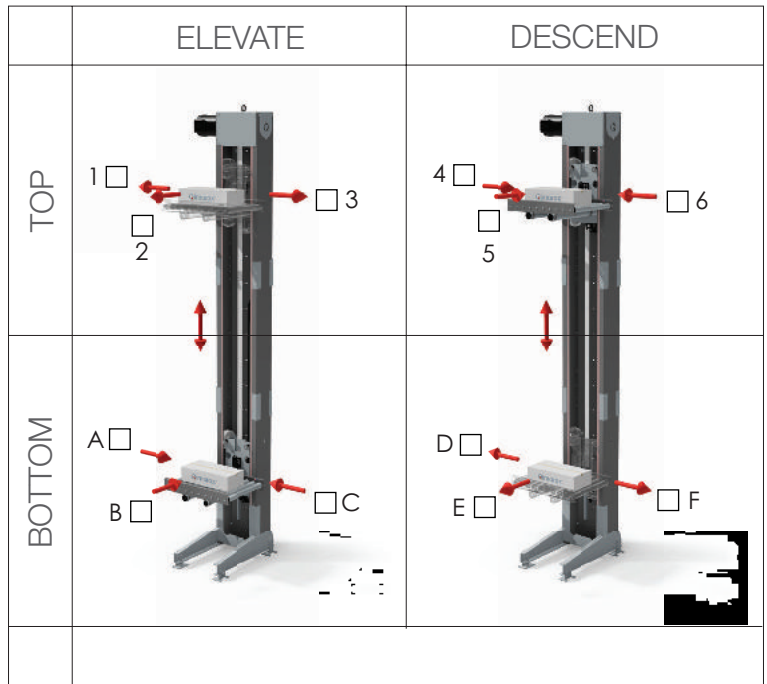

Suitable for

- Carton Trays • Bins • Tires • Books • Cardboard boxes • Shrink wrapped products • Soft parcels • Magazines
- Newspaper bundles • Frozen foods • Trays • Packaged bottles • Boxes • Bags • Totes